

1 A comprehensive proteomic and bioinformatics analysis of human
2 spinal cord injury plasma identifies proteins associated with the
3 complement cascade and liver function as potential prognostic
4 indicators of neurological outcome

5 Gabriel Mateus Bernardo Harrington, PhD* Paul Cool, MD[†]
6 Charlotte Hulme, PhD Jessica Fisher-Stokes, MRes Mandy Peffers, PhD
7 Wagih El Masri, MD Aheed Osman, MBChB Joy Roy Chowdhury, MBBS
8 Naveen Kumar, MBBS Srinivasa Budithi, MD Karina Wright, PhD[‡]

9 2022-10-17

10 **1 Abstract**

11 **1.1 Introduction**

12 Spinal Cord Injury (SCI) is a major cause of disability, with complications post-injury often leading to
13 life-long health issues with need of extensive treatment. Neurological outcome post-SCI can be variable and
14 difficult to predict, particularly in incomplete injured patients. The identification of specific SCI biomarkers in
15 blood, may be able to improve prognostics in the field. This study has utilised proteomic and bioinformatics
16 methodologies to investigate differentially expressed proteins in plasma samples across human SCI cohorts
17 with the aim of identifying prognostic biomarkers and biological pathway alterations that relate to neurological
18 outcome.

19 **1.2 Methods and Materials**

20 Blood samples were taken, following informed consent, from ASIA impairment scale (AIS) grade C “Improvers”
21 (those who experienced an AIS grade improvement) and “Non-Improvers” (No AIS change), and AIS grade
22 A and D at <2 weeks (“Acute”) and approx. 3 months (“Sub-acute”) post-injury. The total protein
23 concentration from each sample was extracted, with pooled samples being labelled and non-pooled samples
24 treated with ProteoMiner™ beads. Samples were then analysed using two 4-plex isobaric tag for relative and
25 absolute quantification (iTRAQ) analyses and a label-free experiment for comparison, before quantifying with
26 mass spectrometry. Data are available via ProteomeXchange with identifiers PXD035025 and PXD035072 for
27 the iTRAQ and label-free experiments respectively.

28 Proteomic datasets were analysed using OpenMS (version 2.6.0). R (version 4.1.4) and in particular, the R
29 packages MSstats (version 4.0.1) and pathview (version 1.32.0) were used for downstream analysis. Proteins of
30 interest identified from this analysis were further validated by enzyme-linked immunosorbent assay (ELISA).

*Keele University

[†]Robert Jones and Agnes Hunt Orthopaedic Hospital NHS Foundation Trust; Keele University

[‡]karina.wright1@nhs.net

31 1.3 Results

32 The data demonstrated proteomic differences between the cohorts, with the results from the iTRAQ approach
33 supporting those of the label-free analysis. A total of 79 and 87 differentially abundant proteins across
34 AIS and longitudinal groups were identified from the iTRAQ and label-free analyses, respectively. Alpha-
35 2-macroglobulin (A2M), retinol binding protein 4 (RBP4), serum amyloid A1 (SAA1), Peroxiredoxin 2,
36 alipoprotein A1 (ApoA1) and several immunoglobulins were identified as biologically relevant and differentially
37 abundant, with potential as individual prognostic biomarkers of neurological outcome. Bioinformatics analyses
38 revealed that the majority of differentially abundant proteins were components of the complement cascade
39 and most interacted directly with the liver.

40 1.4 Conclusions

41 Many of the proteins of interest identified using proteomics were detected only in a single group and therefore
42 have potential as a binary (present or absent) biomarkers, RBP4 and PRX-2 in particular. Additional
43 investigations into the chronology of these proteins, and their levels in other tissues (cerebrospinal fluid
44 in particular) are needed to better understand the underlying pathophysiology, including any potentially
45 modifiable targets. Pathway analysis highlighted the complement cascade as being significant across groups
46 of differential functional recovery.

47 2 Introduction

48 Spinal cord injury (SCI) is the transient or permanent loss of normal spinal sensory, motor or autonomic
49 function, and is a major cause of disability. Globally, SCI affects around 500,000 people each year and is
50 most commonly the result of road traffic accidents or falls.(Crozier-Shaw, Denton, and Morris 2020) Patients
51 typically require extensive medical, rehabilitative and social care at high financial cost to healthcare providers.
52 The lifetime cost of care in the UK is estimated to be £1.12 million (mean value) per SCI, with the total
53 cost of SCI in the UK to the NHS being £1.43 billion in 2016.(McDaid et al. 2019) Individuals with SCI
54 show markedly higher rates of mental illness relative to the general population.(Furlan, Gulasingham, and
55 Craven 2017) Complications arising post-SCI can be long-lasting and often include pain, spasticity and
56 cardiovascular disease, where the systemic inflammatory response that follows SCI can frequently result in
57 organ complications, particularly in the liver and kidneys.(Gris, Hamilton, and Weaver 2008; Sun et al. 2016;
58 Hagen 2015)

59 The recovery of neurological function post-SCI is highly variable, requiring any clinical trials to have an
60 impractically large sample size to prove efficacy, hence the translation of novel efficacious therapies is
61 challenging and expensive.(Spiess et al. 2009) Being able to more accurately predict patient outcomes
62 would aid clinical decisions and facilitate future clinical trials. Therefore, novel biomarkers that allow for
63 stratification of injury severity and capacity for neurological recovery would be of high value to the field.

64 Biomarkers studies in SCI often investigate protein changes in cerebral spinal fluid (CSF) as the closer
65 proximity of this medium is thought to be more reflective of the parenchymal injury.(Brian K. Kwon et al.
66 2019; Hulme et al. 2017) Whilst this makes CSF potentially more informative for elucidating the pathology
67 of SCI, the repeated use of CSF for routine analysis presents challenges in clinical care due to the risk
68 and expense associated with the invasiveness of the collection procedure. In contrast, systemic biomarkers
69 measurable in the blood represent a source of information that can be accessed and interpreted both a lower
70 cost and risk. Studies of traumatic brain injury have demonstrated that protein markers identified in CSF
71 are also detectable in both plasma and serum.(Wang et al. 2018) More recently, circulating white blood cell
72 populations have also been identified as potential SCI injury biomarkers, with a 2021 study showing that
73 elevated levels of neutrophils were associated with no AIS grade conversion, while conversely an increase in
74 lymphocytes during the first week post-SCI were associated with an AIS grade improvement.(Jogia et al.
75 2021)

76 A number of individual proteins have been shown to be altered in the bloods post-SCI, including multiple
77 interleukins (IL), tumour necrosis factor alpha (TNF- α) and C-reactive protein (CRP).(Segal et al. 1997;
78 Hayes et al. 2002; Frost et al. 2005)

79 Further, changes in inflammatory marker levels detected in acute SCI patients were found to be mirrored in
80 donor-matched blood and CSF, albeit at lower absolute concentrations systemically.(Brian K. Kwon et al.
81 2010)

82 Previously, we have shown that routinely collected blood measures associated with liver function and
83 inflammation added predictive value to AIS motor and sensor outcomes at discharge and 12-months post-
84 injury.(Bernardo Harrington et al. 2020; Brown et al. 2019) The current study uses an unbiased shotgun
85 proteomic approach to investigate differentially expressed proteins in SCI patients, coupled with bioinformatics
86 pathway and network analyses.

87 3 Methods and Materials

88 3.1 Patients

89 Blood samples were taken from SCI patients who had provided informed consent and in accordance to
90 ethical provided by the National Research Ethics Service [NRES] Committee North West Liverpool East
91 [11/NW/0876]. “Improvers” were defined as individuals who experienced an AIS grade improvement from
92 admission to a year post-injury, whereas “non-improvers” were defined as patients who saw no change in AIS
93 grade in the same period (Table 1).

Table 1: Patient demographics. \pm denotes interquartile range

	n	Percent
Polytrauma		
Yes	16	41
No	23	59
Gender		
F	13	33
M	26	67
Diabetes		
Yes	7	18
No	32	82
Neurological level		
C	26	67
L	4	10
T	9	23
AIS change		
A	11	28
C	7	18
C->D	10	26
D	11	28
Age at injury (Median years \pm IQR)	53 \pm 26	-

94 3.2 Plasma collection and storage

95 Plasma samples were collected within 2 weeks of injury (acute) and at approximately 3 months post-injury
96 (subacute). Upon collection in EDTA (ethylenediaminetetraacetic acid) coated tubes samples were centrifuged
97 at 600g for 15 minutes, to pellet erythrocytes and the resultant plasma fraction was aspirated and divided
98 into aliquots for long-term storage in -80°C briefly and liquid nitrogen in the longer term.

99 3.3 Sample preparation and analysis using iTRAQ proteomics

100 Thawed plasma samples ($2\mu\text{l}$) each were diluted with distilled water ($98\mu\text{l}$). Total protein was quantified
101 using a Pierce™ 660nm Protein Assay (Thermo Fisher Scientific, Hemel Hempstead, UK)(Stoscheck 1987).

102 A total of 100mg of plasma protein was taken from each sample and pooled equally to form a patient test
103 group. For example, the AIS C improver group was pooled from 10 separate patient samples, 10mg of protein
104 per patient.

105 The pooled plasma samples were precipitated by incubation of the sample in six times the volume of
106 chilled acetone for 1 hour at -20°C . The samples were then centrifuged at $6,000\text{G}$ for 10 minutes at 4°C ,
107 and re-suspended in $200\mu\text{l}$ of triethylammonium bicarbonate buffer. Sequencing Grade Modified Trypsin
108 ($10\mu\text{g}/85\mu\text{g}$ of protein; Promega, Madison, WI, USA) was then added to the samples for overnight digestion
109 at 37°C . Peptides underwent reduction and alkylation (according to the manufacturer's instructions; Applied
110 Biosystems, Bleiswijk, The Netherlands). Tryptic digests were labelled with iTRAQ tags (again according
111 to the manufacturer's instructions for the iTRAQ kit), before being pooled into test groups and dried in a
112 vacuum centrifuge. Two individual iTRAQ experiments were set up, the first to assess acute and sub-acute
113 improvers or non-improvers and the second to assess acute improvers and non-improvers to AIS grade A and
114 D patients. The following tags were used for each group of patient samples 114 tag - acute improvers, 115
115 tag - sub-acute improvers, 116 tag - acute non-improvers and 117 tag - sub-acute non-improvers for run 1
116 and 114 tag - acute improvers, 115 tag - acute non-improvers, 116 tag - AIS grade A and 117 tag - AIS grade
117 D for run 2.

118 3.3.1 iTRAQ mass spectrometry analysis

119 The samples were analysed at the BSRC St. Andrews University Mass Spectrometry and Proteomics Facility.
120 A total of 12 SCX fractions were analysed by nano-electrospray ionisation-liquid chromatography/tandem
121 mass spectrometry (LC-MS/MS) using a TripleTOF 5600 tandem mass spectrometer (AB Sciex, Framingham,
122 MA, USA) as described previously.(Fuller et al. 2015) Each fraction ($10\mu\text{l}$) was then analysed by nanoflow
123 LC-ESI-MSMS, as described previously.

124 The mass spectrometry proteomics data have been deposited to the ProteomeXchange Consortium via the
125 PRIDE partner repository with the dataset identifier PXD035025 and 10.6019/PXD035025.(Perez-Riverol et
126 al. 2021)

127 3.4 Sample preparation and analysis using label-free proteomics

128 No sample pooling was used, and so each of the 73 samples were maintained separately throughout protein
129 equalisation, mass spectrometry, and label-free quantification steps. Thus, protein abundance was quantified
130 for each sample, whereupon mean protein abundance across experimental groups was calculated to assess
131 protein changes.

132 To reduce the dynamic range of proteins, ProteoMiner™ beads (BioRad, Hemel Hempstead, UK) were
133 used.(Boschetti and Righetti 2008) Total protein was quantitated with a Pierce™ 660nm Protein Assay
134 (Thermo Fisher Scientific, Hemel Hempstead, UK), whereupon 5mg of total protein was applied to Pro-
135 teoMiner™ beads, and processed as described previously.(Stoscheck 1987; Peffers et al. 2015)

136 3.4.1 Label free mass spectrometry analysis

137 Tryptic peptides were subjected to LC-MC/MC via a 2-h gradient on a NanoAcquity™ ultraperformance
138 LC (Waters, Manchester, UK) connected to a Q-Exactive Quadrupole-Orbitrap instrument (Thermo-Fisher
139 Scientific Hemel Hempstead, UK).

140 The Q-Exactive was operated in a data dependent positive electrospray ionisation mode, automatically
141 switching between full scan MS and MS/MS acquisition. Survey full scan MS spectra (m/z 300–2000) were
142 acquired in the Orbitrap with $70,000$ resolution (m/z 200) following accumulation of ions to 1×10^6 target
143 value based on the predictive automatic gain control values from the previous full scan. Dynamic exclusion
144 was set to 20s, the 10 most intense multiply charged ions ($z \geq 2$) were sequentially isolated and fragmented

145 in the octopole collision cell by higher energy collisional dissociation (HCD), with a fixed injection time of
146 100ms and 35,000 resolution. The following mass spectrometric conditions were used: spray voltage, 1.9kV,
147 no sheath or axillary gas flow; normalised HCD collision energy 30%; heated capillary temperature, 250°C.
148 MS/MS ion selection threshold was set to 1×10^4 count and 2Da isolation width was set.

149 The mass spectrometry proteomics data have been deposited to the ProteomeXchange Consortium via the
150 PRIDE partner repository with the dataset identifier PXD035072 and 10.6019/PXD035072.(Perez-Riverol et
151 al. 2021)

152 3.5 iTRAQ OpenMS analysis

153 TripleTOF 5600 tandem mass spectrometer output files produced in the ABSciex proprietary .wiff file
154 format were converted to an open file format, .mzML for analysis with OpenMS (version 2.6.0). The docker
155 image of ProteoWizard version 3.0.20287 was used for conversion, and peak picking was applied on conversion
156 (Chambers et al. 2012). OpenMS version 2.6.0 was used for further analysis.(Röst et al. 2016) Unless
157 otherwise stated, default arguments were used. The 12 fraction files were merged and sorted by retention
158 time. A decoy database was generated with `DecoyDatabase` and the `-enzyme` flag set to `Trypsin`, the human
159 reference proteome was taken from Uniprot (Proteome ID: UP000005640, downloaded: 2020-10-01), as was
160 the .fasta for porcine trypsin (Entry: P00761, downloaded: 2020-10-01).(The UniProt Consortium 2021)

161 The `MSFGPlusAdapter` was used to run the search. For the `-fixed_modifications` “Methylthio (C)”
162 and “iTRAQ4plex (N-term)” were passed due to the alkylating agent used in sample preparation and
163 to account for the N-terminus modifications made by iTRAQ tags. “Oxidation (M)” was passed to
164 `-variable_modifications` to reflect the likely occurrence of methionine oxidation. To reflect the instrument
165 the following flags were also set: `-precursor_mass_tolerance 20 -enzyme Trypsin/P -protocol iTRAQ`
166 `-instrument high_res`.

167 To annotate the search results `PeptideIndexer` and `PSMFeatureExtractor` were used. For peptide level
168 score estimation and filtering `PercolatorAdapter` was used with the following arguments: `-score_type`
169 `q-value -enzyme trypsinp`. `IDFilter` was used to filter to a peptide score of 0.05 with `-score:pep 0.05`

170 `IsobaricAnalyzer` with `-type itraq4plex` was used with the merged .mzML files to assign protein-peptide
171 identifications to features or consensus features with `IDMapper`. The files for each run output by `IDMapper`
172 were then merged with `FileMerger`. Bayesian score estimation and protein inference was performed
173 with `Epifany` and the following flags: `-greedy_group_resolution remove_proteins_wo_evidence`
174 `-algorithm:keep_best_PSM_only false` Decoys were removed and 0.05 FDR filtering was done via
175 `IDFilter` with `-score:protgroup 0.05 -remove_decoys`. Finally, `IDConflictResolver` was used
176 to resolve ambiguous annotations of features with peptide identifications, before quantification with
177 `ProteinQuantifier`.

178 3.6 Label free OpenMS analysis

179 For quantification, the raw spectra files were analysed via OpenMS (version 2.6.0) command line tools,
180 with the workflow from the prior section (3.5) adapted to suit a label-free analysis. The files were first
181 converted from the proprietary .Raw format to the open .mzML standard with the `FileConverter` tool via
182 the open-source `ThermoRawFileParser`.(Röst et al. 2016; Hulstaert et al. 2020) Unless otherwise stated,
183 default arguments were used throughout.

184 The decoy database generated in the prior section (iTRAQ OpenMS analysis) was also re-used. The
185 `CometAdapter` was used to run the search.(Eng, Jahan, and Hoopmann 2013) Fixed modifications were set to
186 “Carbamidomethyl (C)” and “Oxidation (M)” was set as a variable modification. To reflect the instrument
187 the following flags were also set: `-precursor_mass_tolerance 20 -isotope_error 0/1`.

188 To annotate the identified peptides with proteins the `PeptideIndexer` tool was used. `PeptideIndexer`
189 and `PSMFeatureExtractor` were used for annotation. For peptide level score estimation and filtering
190 `PercolatorAdapter` was used with the following flags: `-score_type q-value -enzyme trypsin`. `IDFilter`
191 was used to filter to a peptide score of 0.01 with `-score:pep 0.01` followed by `IDScoreSwitcher` with the

192 following flags: `-new_score "MS:1001493" -new_score_orientation lower_better -new_score_type`
193 `"pep" -old_score "q-value"`. The ProteomicsLFQ was used for subsequent processing with the flags:
194 `-proteinFDR 0.05 -targeted_only true`. The `-out_msstats` flag was also used to produce quantitative
195 data for downstream statistical analysis with the R package MSstats.(Choi et al. 2014)

196 **3.7 Network and pathway analysis**

197 The Bioconductor package ReactomePA, which employs the open-source, open access, manually curated and
198 peer-reviewed pathway database Reactome was used for network analysis.(Yu and He 2016; Jassal et al. 2020)

199 **3.8 Enzyme-linked immunosorbent assays**

200 Four proteins identified by the iTRAQ analysis were measured by enzyme-linked immunoabsorbent assay
201 (ELISA) from non-pooled samples to validate the iTRAQ findings.

202 These proteins were alpha-2-macroglobulin (A2M), retinol binding protein 4 (RBP4), serum amyloid A1
203 (SAA1) and apolipoprotein A1 (ApoA1). They were selected for their biological relevance and differential
204 abundance between AIS C improvers and non-improvers, implying potential as biomarkers of neurological
205 outcome prediction. A2M, RBP4 and SAA1 were assessed using a human DuoSet® ELISAs (R&D Systems,
206 Abingdon, UK). ApoA1 was assessed using a human Quantikine® ELISA (R&D Systems, Abingdon, UK).
207 Samples were diluted 1:600,000 for A2M and RBP4, 1:100 for SAA1 and 1:20,000 for ApoA1 in the respective
208 assay kit diluent. Samples that were above the assay detection limit were rerun at 1:300 and 1:40,000 for SAA1
209 and ApoA1 respectively. All ELISAs were carried out according to the manufacturer's protocol. Protein
210 concentrations were normalised to the sample dilution factor. Statistical analysis was performed using the
211 statistical programming language R version 4.2.1 (2022-06-23). Pairwise t tests with bonferroni adjusted
212 P-values with the R `rstatix` package were used to assess differential abundance.

213 **4 Results**

214 Plasma from American Spinal Injury Association (ASIA) grade C SCI patients (total n=17) contrasting
215 those who experienced an AIS A grade conversion (n=10), and those who did not (n=7) collected within 2
216 weeks, and at approximately 3 months post-injury (Improvers n=9 vs Non-improvers n=6). Relative protein
217 abundance in AIS grade A (n=10) and grade D (n=11) patients was also examined.

218 In the interest of brevity, only the plots of acute and subacute AIS C improvers VS non-improvers are included
219 here, please see the supplemental data for the other comparisons (section 5).

220 **4.1 iTRAQ analyses**

221 **4.2 Differential protein abundances**

222 AIS C improvers had 18 more abundant proteins and 49 less abundant proteins at the acute phase relative to
223 non-improvers. Similarly, at the subacute phase, AIS C improvers had 34 more abundant proteins and 34 less
224 abundant proteins relative to non-improvers. The AIS A group had 56 more abundant and 9 less abundant
225 proteins respectively relative to non-improvers. Acutely, AIS C improvers relative to AIS A and D had 21
226 and 53 more abundant and 46 and 12 less abundant proteins.

227 Please see the Tables S2, S3 & S4 for a full list of protein fold change changes.

228 **4.3 Heatmaps**

229 The majority of the pathways associated with the proteins identified by these iTRAQ experiments are related
230 to the complement cascade and platelet activity (Figure 1, 2). There are also several pathways implicated in
231 metabolic processes, particularly with apolipoproteins and retinoids.

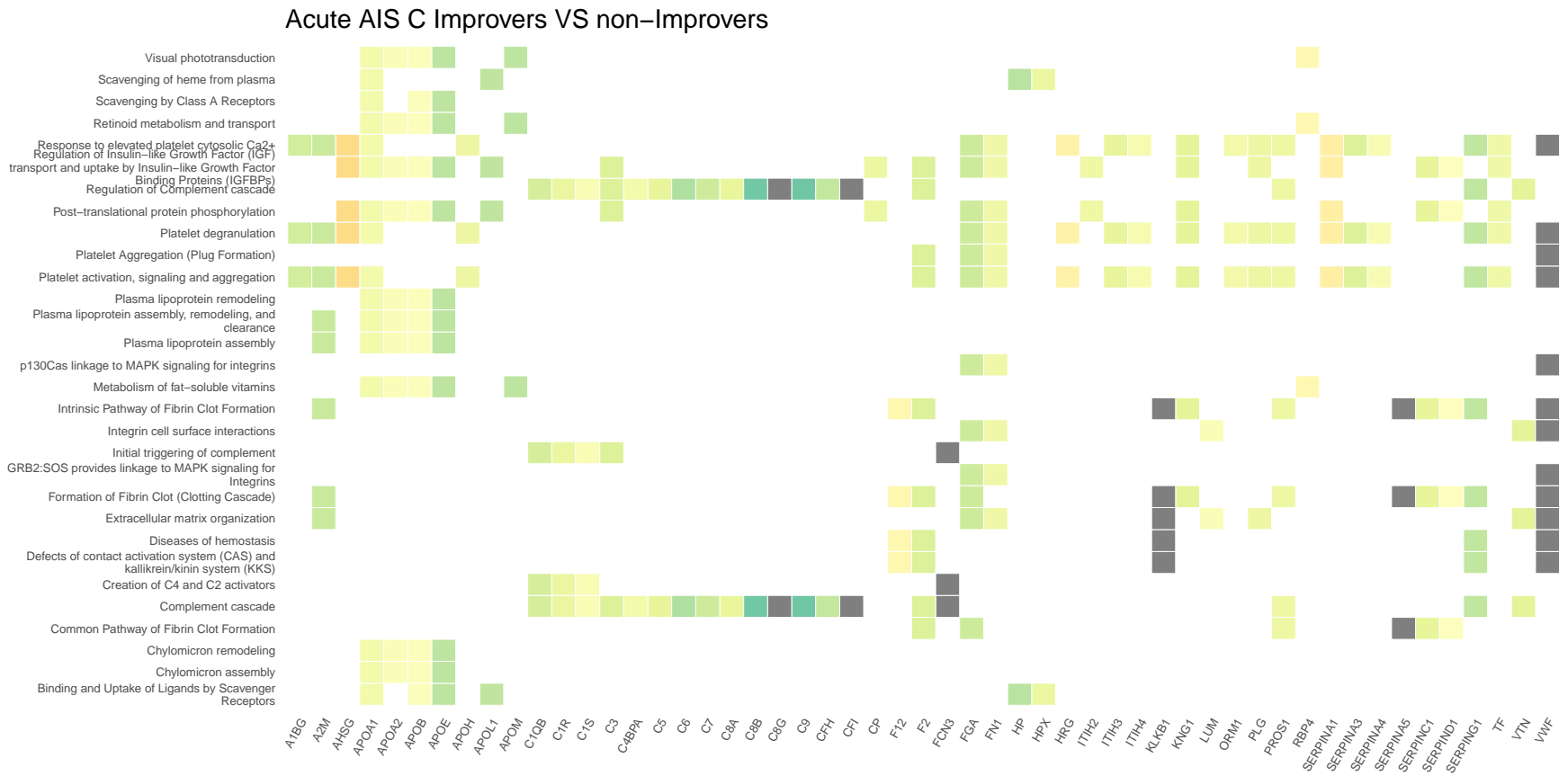

Figure 1: Heatmap denoting the log₂ fold change of proteins in plasma collected 2-weeks post-injury, and the biological pathways these proteins are associated with on Reactome. This compares AIS C SCI patients who experienced an AIS grade improvement and those who did not.

²³² Similarly to the iTRAQ data, many of the Reactome pathways are associated with the complement cascade
²³³ and platelets activation (Figures 3, 4).

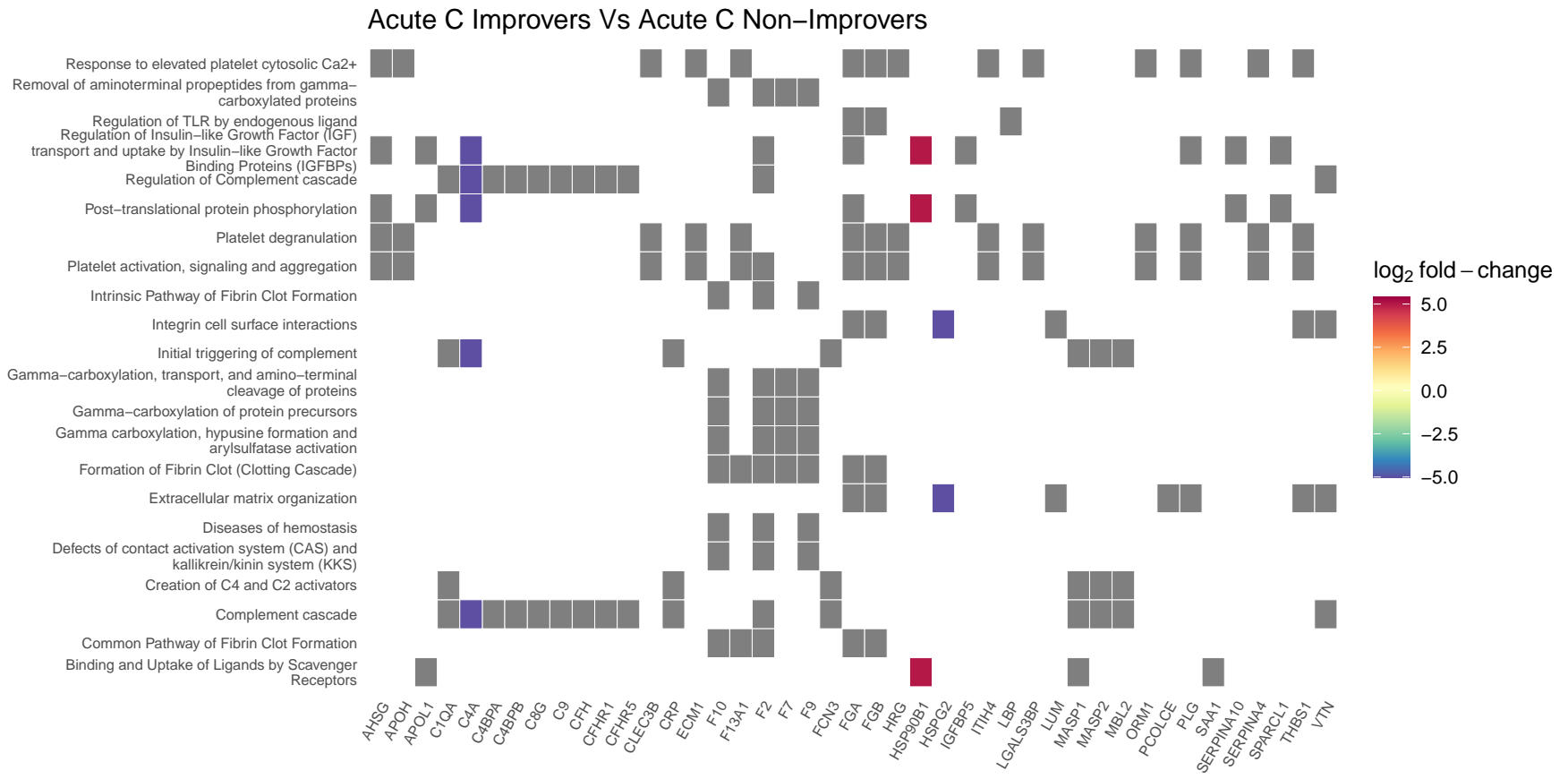

Figure 3: Heatmap denoting the log₂ fold change of proteins in plasma collected 2-weeks post-injury, and the biological pathways these proteins are associated with on Reactome. This compares AIS C SCI patients who experienced an AIS grade improvement and those who did not. Grey blocks denote proteins not present in the comparison.

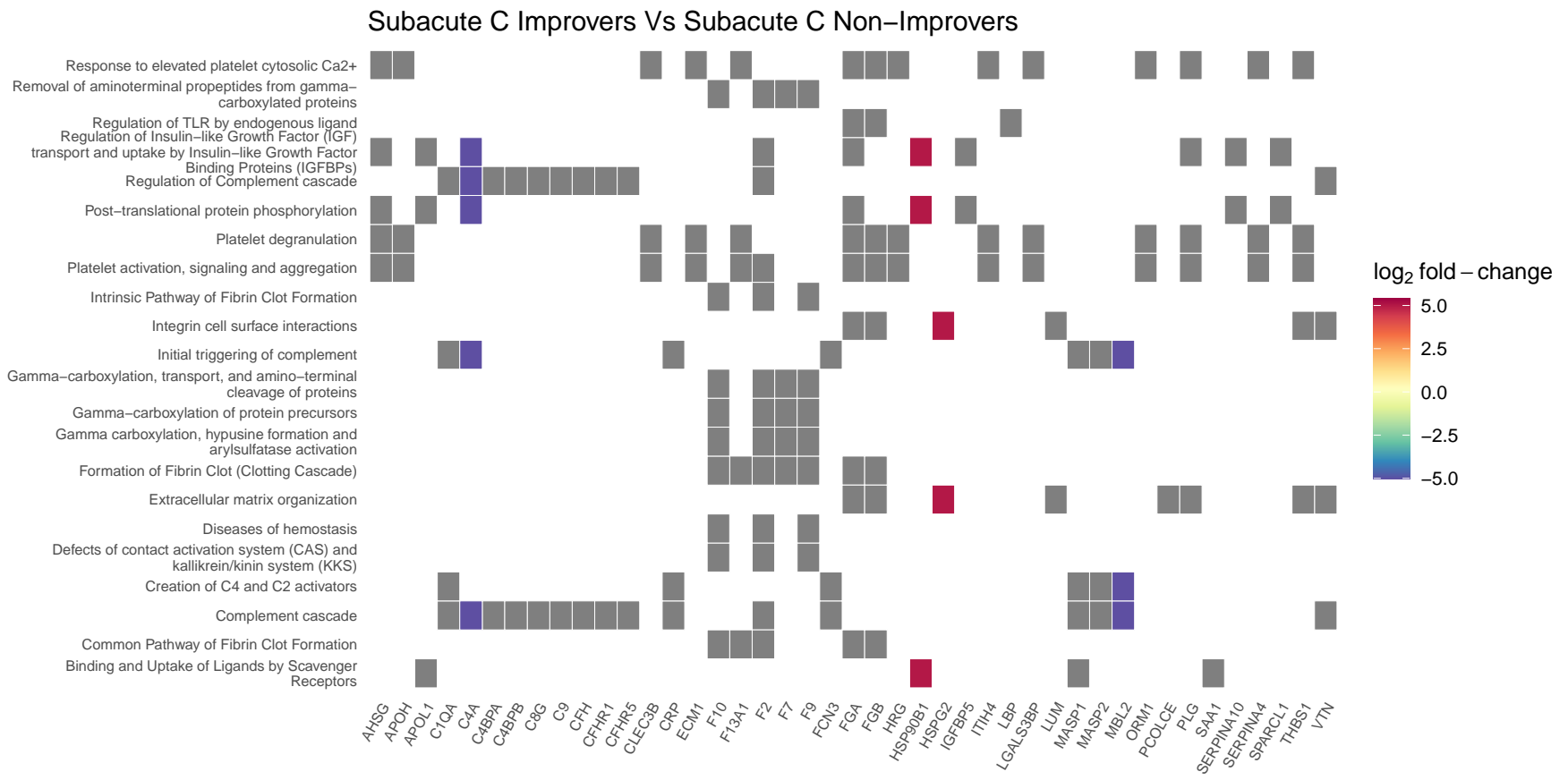

Figure 4: Heatmap denoting the log₂ fold change of proteins in plasma collected 3-months post-injury, and the biological pathways these proteins are associated with on Reactome. This compares AIS C SCI patients who experienced an AIS grade improvement and those who did not. Grey blocks denote proteins not present in the comparison.

234 **4.4 Network analysis of Differentially Abundant Proteins between AIS C im-**
235 **provers and non-improvers**

236 Similar to the heatmaps, network plots highlighted that the majority of proteins changes were associated
237 with the complement cascade and pathways linked to platelet activity (Figure 5, 6). Several proteins were
238 also associated with the regulation of insulin-like growth factor.

Acute AIS C Improvers VS non-Improvers

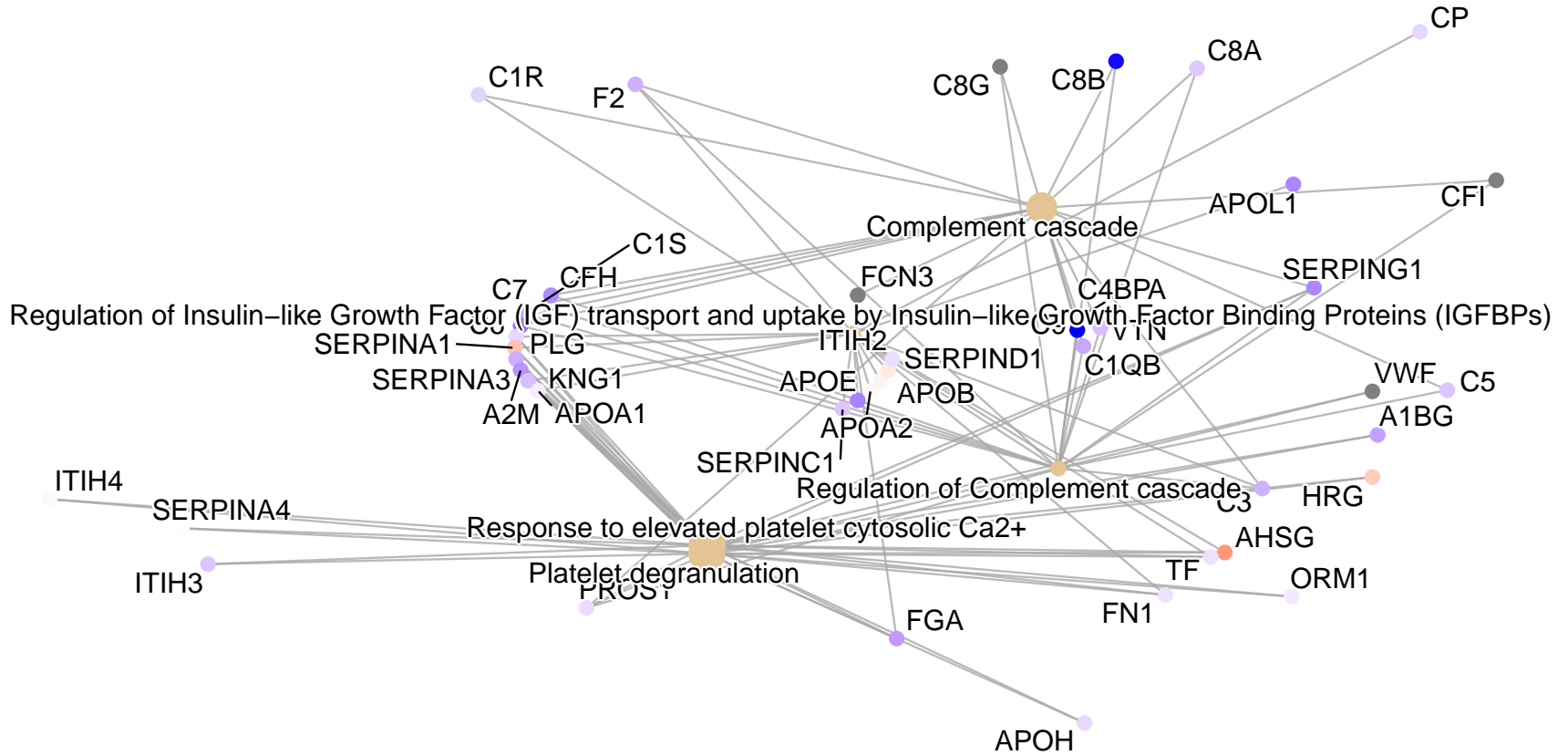

Figure 5: Network plot denoting the log₂ fold change of proteins in plasma collected 2-weeks post-injury, and the biological pathways these proteins are associated with on Reactome. This compares AIS C SCI patients who experienced an AIS grade improvement and those who did not.

Subacute AIS C Improvers VS non-Improvers

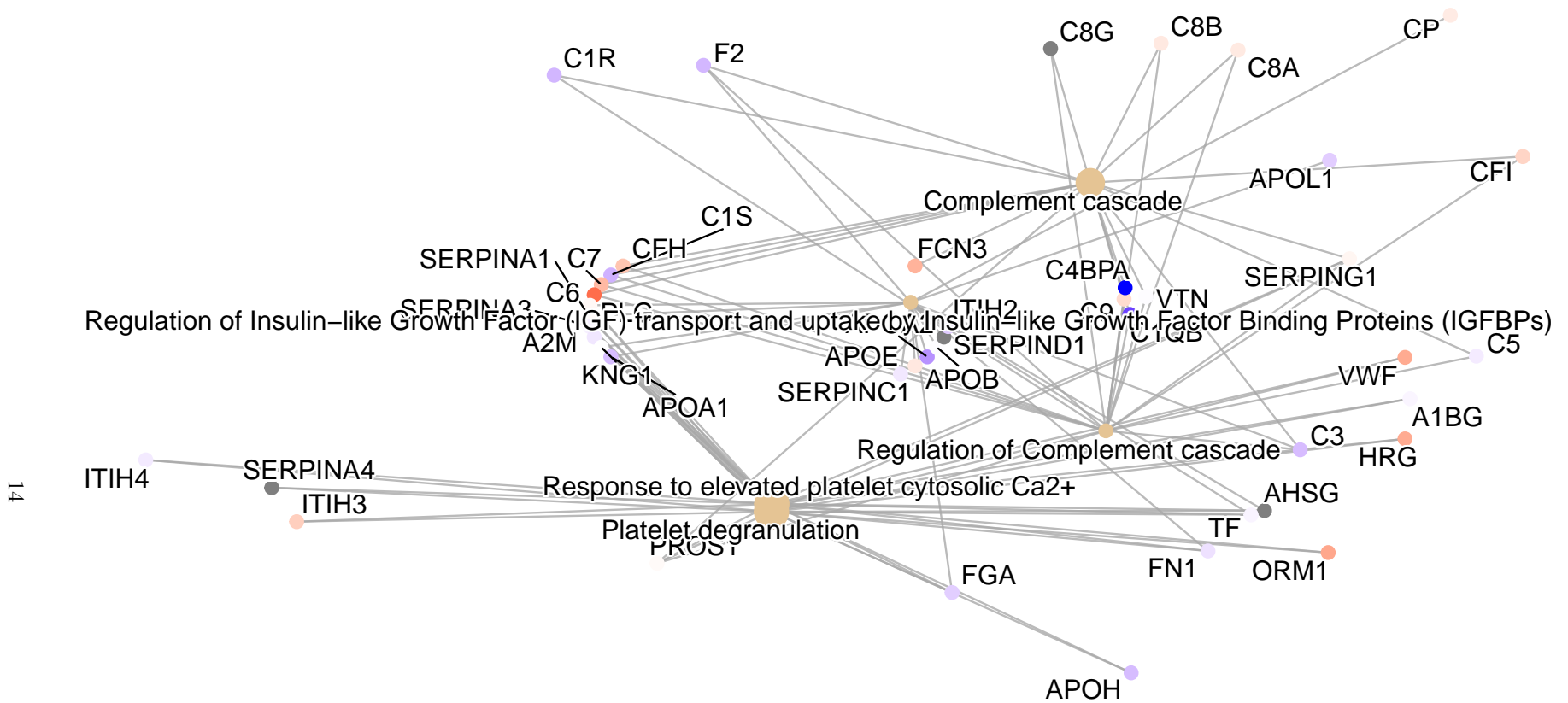

Figure 6: Network plot denoting the log₂ fold change of proteins in plasma collected 3-months post-injury, and the biological pathways these proteins are associated with on Reactome. This compares AIS C SCI patients who experienced an AIS grade improvement and those who did not.

239 Similarly to the heatmaps and the iTRAQ data, network plots derived using the label-free data highlight the
240 majority of differential proteins are associated with the complement cascade and pathways linked to platelets
241 (Figures 7, 8).

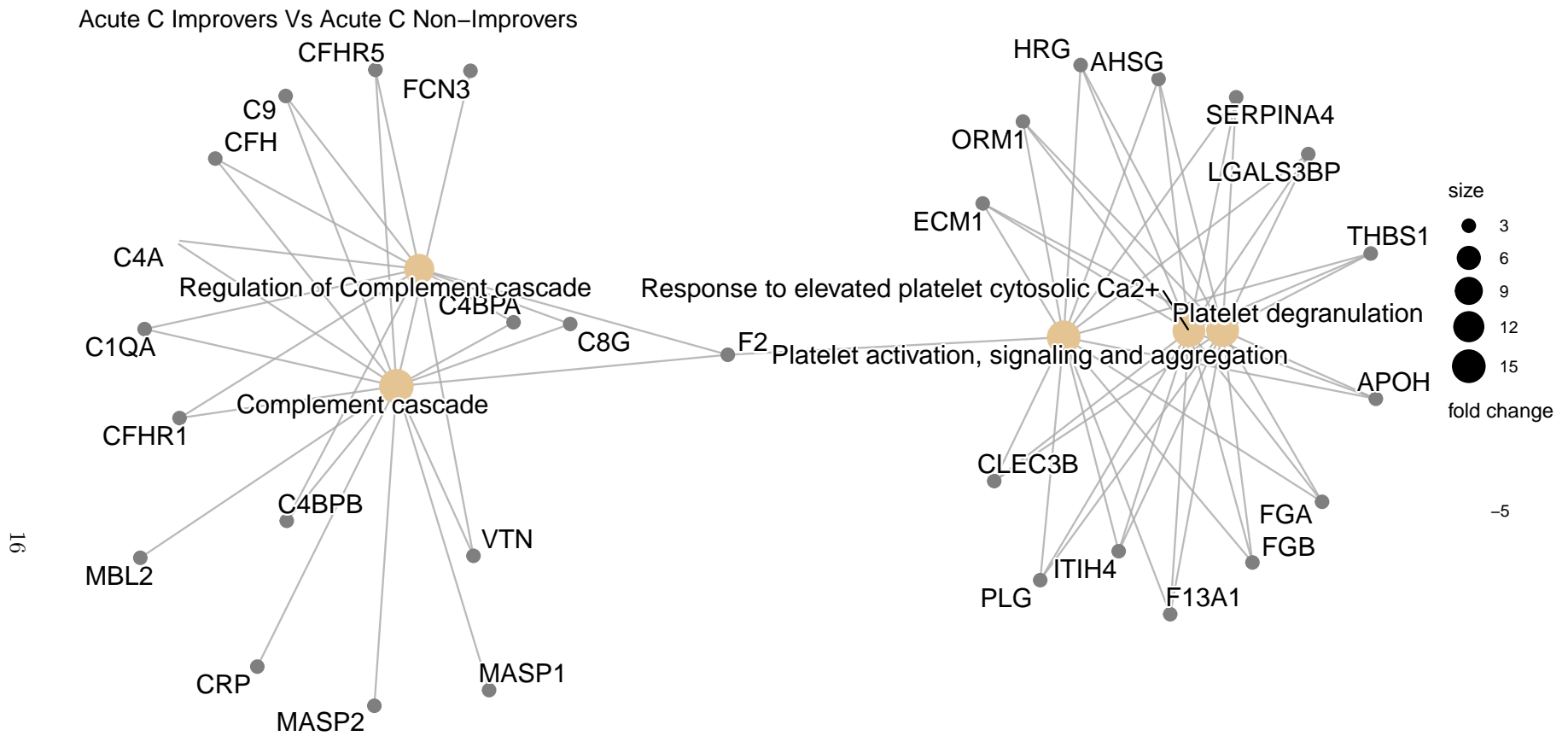

Figure 7: Network plot denoting the \log_2 fold change of proteins in plasma collected 2-weeks post-injury, and the biological pathways these proteins are associated with on Reactome. This compares AIS C SCI patients who experienced an AIS grade improvement and those who did not.

Subacute C Improvers Vs Subacute C Non-Improvers

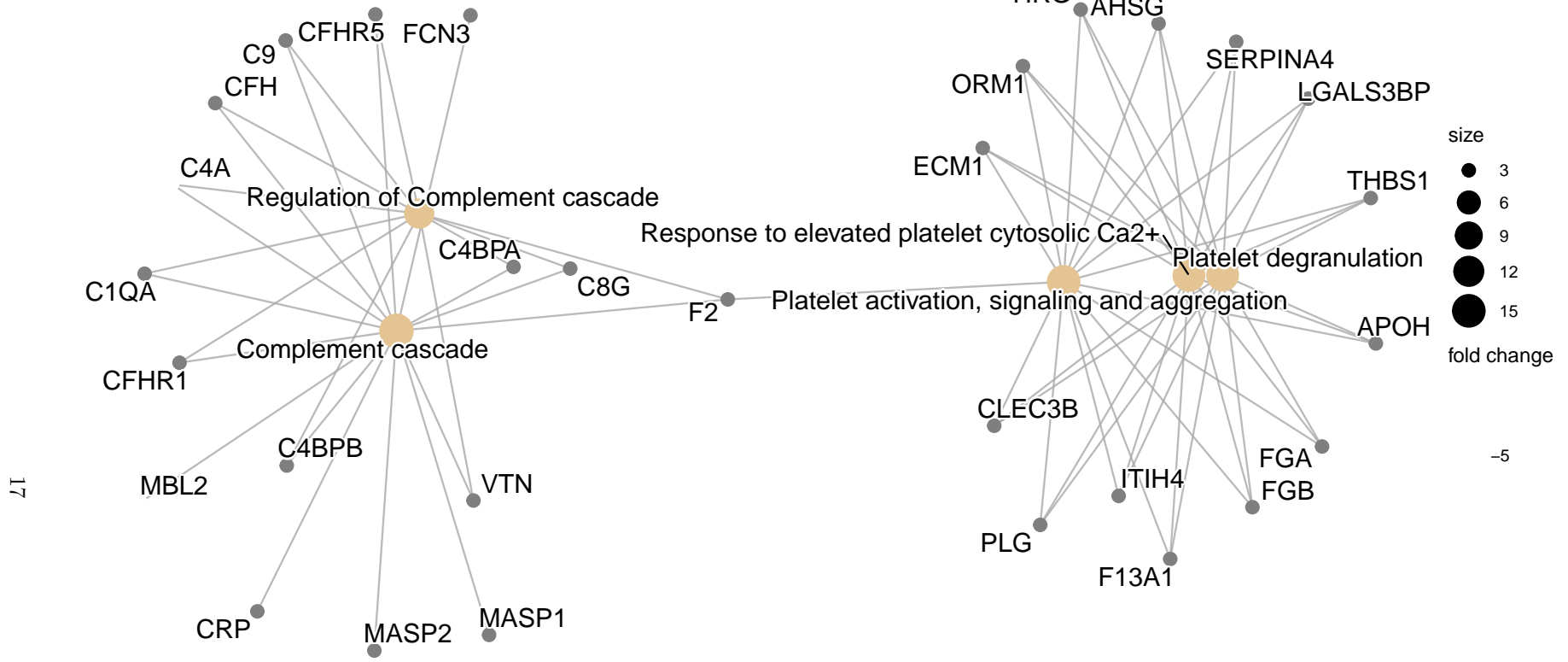

Figure 8: Network plot denoting the \log_2 fold change of proteins in plasma collected 3-months post-injury, and the biological pathways these proteins are associated with on Reactome. This compares AIS C SCI patients who experienced an AIS grade improvement and those who did not.

242 4.5 Pathway analysis of Differentially Abundant Proteins between AIS C im- 243 provers and non-improvers

244 Pathway analysis via the pathview R package returned the complement and coagulation cascade to be
245 on the sole significant KEGG pathway to derive from the OpenMS analysed data. The majority of the
246 proteins present in this pathway were less abundant in the 2-week post-injury plasma of AIS C patients who
247 experienced an AIS grade conversion and those who did not (Figure 9).

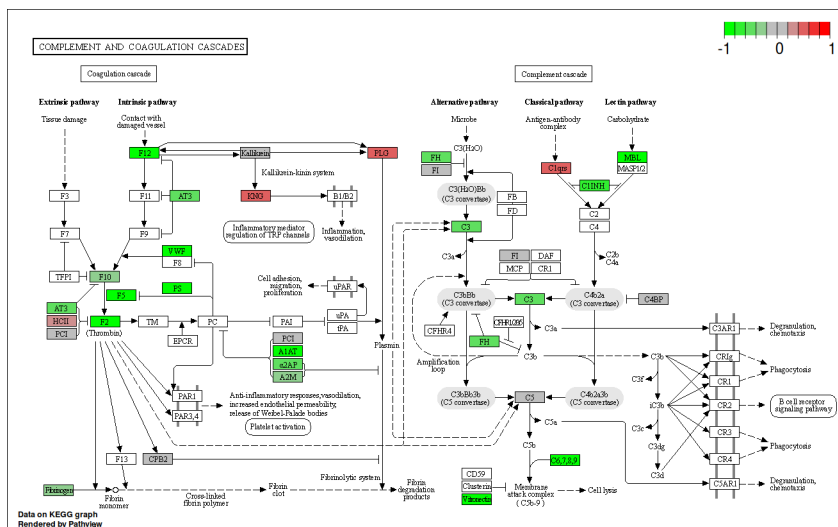

Figure 9: KEGG complement cascade pathway annotated with log₂ fold change of proteins in plasma collected 2-weeks post-injury. This compares AIS C SCI patients who experienced an AIS grade improvement and those who did not.

248 Similarly to the iTRAQ pathway analysis, the label free data analysed via the pathview R package returned
249 the complement and coagulation cascade to be the sole significant KEGG pathway derived from the OpenMS
250 analysed data. The majority of the proteins present in this pathway were less abundant 2-weeks post-injury
251 in the plasma of AIS C patients who experienced an AIS grade conversion than those who did not (Figure
252 10).

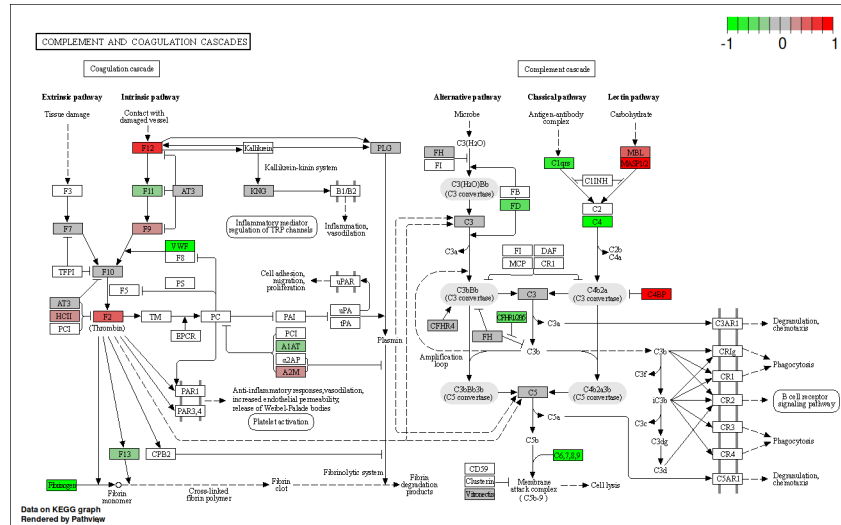

Figure 10: KEGG complement cascade pathway annotated with \log_2 fold change of proteins in plasma collected 2-weeks post-injury. This compares AIS C SCI patients who experienced an AIS grade improvement and those who did not.

253 4.6 Validation of Proteomic Data using ELISA

254 No statistically significant difference between groups for A2M abundance in plasma via DuoSet® ELISAs,
 255 though there were outliers in the AIS A and D groups, and particularly in the AIS C patients at 3-months
 256 who did not experience an AIS grade conversion (Figure 11).

257 A significant difference was found between AIS C non-improvers at 2-weeks and AIS D for SAA1, with outliers
 258 in AIS C non-improvers at 2-weeks, and both AIS C improvers and non-improvers at 3-months post-injury
 259 (Figure 11). For ApoA1 plasma abundance estimated via Quantikine® ELISAs, statistically significant
 260 differences were found between AIS C improvers at 2-weeks and both AIS C improvers and non-improvers at
 261 3-months, AIS C 3-month improvers and AIS A and D, and AIS C 3-month non-improvers and AIS A and D
 262 (Figure 11). A statistically significant difference was also found between AIS C improvers and non-improvers
 263 at 2-weeks post-injury for RBP4 (Figure 11).

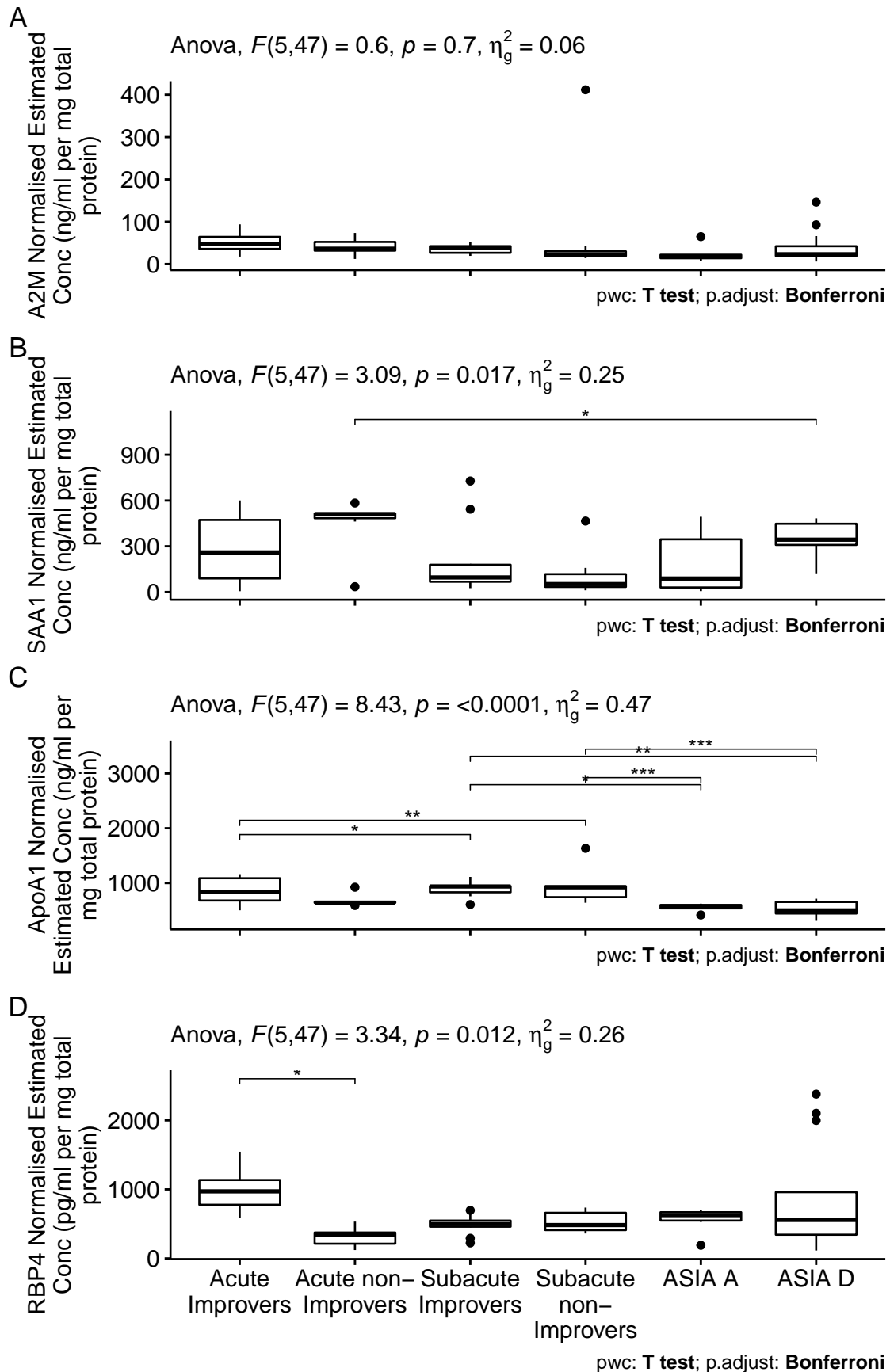

Figure 11: Normalised estimated concentration of α -2-macroglobulin (A), serum amyloid A1 (B), apolipoprotein A1 (C) and retinol binding protein 4 (D). Estimates were calculated from the optical density of a standard curve produced via a DuoSet® ELISA. Plasma from each patient that made up the pooled iTRAQ samples was assayed and pairwise t-tests with bonferroni adjusted P-values were performed to assess differential abundance.

264 4.7 Comparing iTRAQ and label-free proteins

265 A total of 87 and 79 unique proteins were identified across the label-free and iTRAQ experiments respectively,
266 with a modest overlap of 26 proteins found using both techniques.

267 5 Discussion

268 This is the first study, to our knowledge, to investigate the plasma proteome in SCI patients whose AIS scores
269 either improved or did not improve post injury and also to compare these to AIS grade A and D patients.
270 We have used two proteomic techniques allowing us to profile both high and low abundance proteins, in
271 order to identify protein candidate biomarkers which may have potential to predict neurological improvement
272 within the acute setting. Moreover, this data can better inform us of the biology underlying neurological
273 improvement or stability in a cohort of patients being conservatively managed post SCI.

274 Briefly, for processing of proteomic data, we compared the performance of the mass spectrometry vendor
275 (ABSciex) provided ProteinPilot (version 4.5) and OpenMS (version 2.6.0). As there were only modest
276 difference in both the proteins identified and the respective fold changes (data not shown), we opted to use
277 OpenMS for the greater transparency and reproducibility it offers as open-source software.

278 This study has highlighted a number of proteins that may be able to discriminate in, the acute phase following
279 injury, between AIS grade C patients who either improve or do not improve by an AIS grade following SCI.
280 The most promising of these is Retinol Binding Protein 4 (RBP4) which was demonstrated to be increased
281 in improvers compared to non-improvers in the acute phase. Further this change could be confirmed using
282 ELISA, which may provide a more clinically useful means of assessment on a wide scale.

283 RBP4 is synthesised in the liver and binds retinol that is released following vitamin A deficiency.(Peterson
284 1971) Once delivered to target cells, retinol can either be converted to retinaldehyde, which is required for
285 functional vision, or oxidised to retinoic acid, which is a ligand for nuclear receptors, thus regulating gene
286 expression.(Lane and Bailey 2005; Balmer and Blomhoff 2002) The role of retinoid signalling in spinal cord
287 and motor neuron differentiation, including development of regions of the spinal cord has been outlined, and
288 implies a possible involvement in maintaining motor neuron integrity.(Colbert et al. 1995; Sockanathan and
289 Jessell 1998) The mRNA of a rodent homologue of RBP was found to be up-regulated at 24 hours post-SCI
290 and may promote cell proliferation and regeneration by increasing retinoid metabolism.(Song et al. 2001;
291 Hurst et al. 1999)

292 Another study of amyotrophic lateral sclerosis (ALS), a neurodegenerative disease, comparing gene expression
293 between post-mortem spinal cord samples of ALS and controls similarly observed up-regulation of RBP1 in
294 ALS spinal cord.(Malaspina, Kaushik, and Bellerocche 2001) Furthermore, a transgenic mouse study reported
295 retinoid signalling may contribute to the retained plasticity and regenerative potential of the mature spinal
296 cord.(Haskell et al. 2002) Collectively, these results might support a hypothesis that AIS C improvers have
297 increased levels of RBP4 and this relates to improved capacity for neuronal regeneration/plasticity. Whether
298 this is due to increased expression or due to higher vitamin A dietary intake is unclear from this data.

299 Alongside RBP4, a number of other protein abundance differences across the different biological comparisons
300 were identified in proteins associated with liver function. Our previous work investigating the potential
301 of routinely measured haematological analytes for predicting neurological outcome in SCI patients also
302 highlighted several proteins that were linked with liver function; thus providing further support to the theory
303 that liver status is relevant to differential functional recover.(Brown et al. 2019; Bernardo Harrington et al.
304 2020) The pathway analysis specifically indicated that the acute phase response (APR) is implicated.

305 The APR is the bodies first response to infection or injury, including SCI. This systemic response is largely
306 coordinated by factors released from the liver, but the APRs effects extend to multiple peripheral organs
307 including the kidneys, lungs and spleen.(Bao et al. 2012; Campbell, Zahid, et al. 2008; Fleming et al. 2012;
308 Gris, Hamilton, and Weaver 2008) This hepatic response is typically transient and quickly fades, but prolonged
309 liver inflammation and pathology has been observed in rodent SCI models.(Goodus et al. 2018; Sauerbeck et
310 al. 2014) Basic liver functions are chronically impaired by SCI, including metabolising carbohydrates, fats and

311 proteins, storage of minerals vitamins and glycogen and filtering blood from the digestive tract.(García-López
312 et al. 2007; DeLeve 2007; Farkas and Gater 2018; Chow et al. 2012; Sauerbeck et al. 2014)

313 The acute (1-7 days) liver response to SCI is well documented; the inflammatory cytokines including $TNF\alpha$,
314 $IL-1\alpha$, $IL-1\beta$ and $IL-6$, released at the injury site, reach the liver through the bloodstream.(Fleming et al.
315 2012; Hundt et al. 2011) This provokes the liver to enter the APR and produce acute phase proteins thus
316 stimulating a greater immune response.(Anthony and Couch 2014; Fleming et al. 2012) The hepatocytes that
317 make up the majority of the liver biomass, express receptors that bind the aforementioned inflammatory
318 cytokines; similarly the hepatic macrophage Kupffer cells also bind these cytokines, complement proteins
319 and lipopolysaccharide (LPS) and swiftly remove microorganisms, endotoxins and other debris from the
320 blood.(Yang et al. 2013; Szalai et al. 2000; Crispe 2016; Campbell et al. 2005) Furthermore, it has been
321 suggested that liver inflammation and Kupffer cells activity promote recruitment of leukocytes to the injury
322 site in brain or spinal trauma, potentially enhancing CNS injury.(Anthony and Couch 2014; Campbell et al.
323 2005) For example, a rodent study demonstrated depletion of Kupffer cells prior to injury resulted in few
324 neutrophils infiltrating the injury site.(Campbell, Zahid, et al. 2008; Campbell, Anthony, et al. 2008)

325 Another protein that out label-free proteomic data highlights is Peroxiredoxin 2 (PRX-2), which was detected
326 acutely in AIS C improvers and AIS D patients, and subacutely in AIS A and AIS D. Peroxiredoxins are a
327 large and highly conserved family of enzymes that reduce peroxides. PRX-2 is highly abundant in RBCs and
328 intracellularly serves as an important anti-oxidant role in various cells types, including neurons.(Low, Hampton,
329 and Winterbourn 2008) By contrast, extracellular PRX-2 has been suggested to act as an inflammatory DAMP,
330 leading microglia and macrophages to release a plethora of pro-inflammatory factors.(Salzano et al. 2014;
331 Garcia-Bonilla and Iadecola 2012; Shichita et al. 2012) An *in vitro* primary neurons and microglia co-culture
332 study reported PRX-2 activating microglia via TLR-4, potentially leading to neuronal apoptosis.(Lu et al.
333 2018) A murine study found over-expression of PRX-2 attenuated oxidative stress and neuronal apoptosis
334 following subarachnoid haemorrhage.(Lu et al. 2019) Over-expression of PRX-2 is speculated to protect
335 again ischaemic neuronal injury by modulating the redox-sensitive thioredoxin-apoptosis signal-regulating
336 kinase (ASK) 1 signalling complex.(Gan et al. 2012) Several molecular chaperones can interact with ASK1,
337 including thioredoxin and TNF receptor-associated factor 6.(Matsuzawa et al. 2005) The dissociation of the
338 thioredoxin-ASK1 complex activates ASK1. PRX-2 is oxidised after scavenging free radicals, whereupon its
339 antioxidant activity is reduced. This inactivation can be reversed by the thioredoxin-thioredoxin reductase
340 system, whereby oxidised PRX-2 can regain its activity by reducing thioredoxin, leading to the dissociation of
341 the thioredoxin-ASK1 complex.(Rhee and Woo 2011) Additionally, oxidised PRX-1 can inhibit ASK1-induced
342 apoptosis via the thioredoxin-binding domain on ASK1.(Kim, Kim, and Lee 2008)

343 The presence of PRX-2 in acute AIS C improvers and absence in acute C non-improvers suggests the protein
344 could indicate a more protective action against oxidative stress, and implies the protein has potential value as
345 a biomarker of functional outcomes. Similarly, PRX-2 may be acting as a healthy response to trauma-induced
346 oxidative stress in both acute AIS D, although the persistence to the subacute time-point is less clear.
347 Likewise, the presence of PRX-2 in AIS A subacutely, but not acutely is more perplexing. It should be noted
348 that as plasma was used and cells were lysed, there is no distinction between intracellular and extracellular
349 PRX-2 in this data. Perhaps in the more severe AIS A injury, secondary injuries, including oxidative stress,
350 are greater and so persist to the subacute time-point. The acute absence may be a result of an overwhelmed
351 physiology unable to respond or prioritise managing oxidative stress.

352 Pathway analysis from both the iTRAQ and label-free experiments identified the complement and coagulation
353 cascades as a significant pathway of interest. More broadly, the trend in this data is for proteins in the
354 complement pathway is lower abundance, or inhibitory proteins such as C4BP to be more abundant, in the
355 acute improvers. C3 for instance, cleavage of which is vital for complement activation, was less abundant
356 in acute AIS C improvers relative to non-improvers. This finding is in line with a genetic C3 knockout
357 study in mice which reported better neurological scores 2 days post-injury, reduced residual consolidated
358 neurological deficit at 21 days and display minor change in reduced gliosis (20% decrease at 1h timepoint)
359 but a three-to-fourfold decrease in neutrophil infiltration, resulting in enhanced regeneration of axons.(Qiao
360 et al. 2006) Another study using a similar C3 knockout model reported improved neurological scores at
361 acute and long-term time points.(Guo et al. 2010) These results imply that the complement cascade is a
362 particularly important component of a differential response to neurological injury which ultimately leads to

363 greater functional recovery. Given the complexity of the complement cascade and the limited time points in
364 this study, further work is needed to elucidate which facets of the cascade are outcome modifying, and at
365 which stages post-injury.

366 AIS A and D samples were included largely to compare to the AIS C improvers. If the improvers were all just
367 a less severe AIS C, we might expect them to be more similar to the AIS D samples, with the non-improvers
368 being closer to the As. As this is not what we observed, we can conclude there is more to the differential
369 functional recovery than initial injury severity.

370 The small number of statistically significant proteins speaks to the variability of human plasma samples, and
371 is likely exacerbated by the inconstant timing of sample collection relative to injury. Thus, a repeat of this
372 experiment with a larger sample size will likely reveal many more proteins of potential interest. Regardless,
373 this study has highlighted RPB4 and PRX-2 as potential biomarkers of functional recover. We have also
374 highlighted the complement cascade as being a particularly important pathway in differential recovery.
375 Additional investigation of these proteins, but also the complement cascade more broadly, particularly at
376 more acute time points, would also be valuable. Furthermore, a metabolomic analysis with a similar samples
377 would greatly compliment this work, particularly with regards to investigating further links to the livers role
378 in neurological recovery. Similarly, this additional work could complement the AIS A and D sample data,
379 which may reveal further insights from this data.

380 Supplementary material

381 5.1 Session Information

```
382 ##  
383 ## platform      aarch64-apple-darwin20  
384 ## arch          aarch64  
385 ## os            darwin20  
386 ## system        aarch64, darwin20  
387 ## status  
388 ## major         4  
389 ## minor         2.1  
390 ## year          2022  
391 ## month         06  
392 ## day           23  
393 ## svn rev       82513  
394 ## language      R  
395 ## version.string R version 4.2.1 (2022-06-23)  
396 ## nickname      Funny-Looking Kid
```

Table S1: Packages Used

package	version	date
base	4.2.1	2022-06-24
MSstats	4.4.1	2022-05-31
STRINGdb	2.8.4	2020-01-10
ReactomePA	1.40.0	2022-04-26
rlang	1.0.6	2022-09-23
bookdown	0.29	2022-09-12
lime	0.5.3	2022-08-18
RColorBrewer	1.1.3	2022-04-03
ggVennDiagram	1.2.2	2022-09-08
DiagrammeR	1.0.9	2022-03-04
lubridate	1.8.0	2021-10-03
patchwork	1.1.2	2022-08-18
cowplot	1.1.1	2020-12-15
readxl	1.4.1	2022-08-17
BiocManager	1.30.18	2022-05-18
knitr	1.40	2022-08-24
rmarkdown	2.17	2022-10-07
data.table	1.14.2	2021-09-23
naniar	0.6.1	2021-05-14
psych	2.2.9	2022-09-12
Hmisc	4.7.1	2022-08-13
Formula	1.2.4	2020-10-16
survival	3.4.0	2022-07-31
lattice	0.20.45	2021-09-18
bibtex	0.5.0	2022-09-23
captioner	2.2.3	2015-07-15
forcats	0.5.2	2022-08-19
stringr	1.4.1	2022-08-20
dplyr	1.0.10	2022-08-31
purrr	0.3.5	2022-09-28
readr	2.1.3	2022-09-30
tidyr	1.2.1	2022-08-31
tibble	3.1.8	2022-07-21
ggplot2	3.3.6	2022-04-27
tidyverse	1.3.2	2022-07-06
kableExtra	1.3.4	2021-02-19

Table S2: OpenMS log₂ fold changes in the plasma proteome of SCI patients from iTRAQ experiments. 'Acute' and 'Subacute' samples collected within 2 week and approximately 3-months post-injury respectively.

gene	Acute AIS C improvers vs non-improvers	Subacute AIS C improvers vs non-improvers	AIS C improvers acute vs subacute	AIS C non-improvers acute vs subacute	AIS C improvers vs non-improvers	AIS A vs D	AIS C improvers vs A	AIS C improvers vs D	AIS C non-improvers vs A	AIS C non-improvers vs D
A1BG	-0.9032	-0.1018	-0.6088	0.1926	0.2253	0.7937	-0.3498	0.4440	-0.5750	0.2187
A2M	-1.0386	-0.2464	-0.6761	0.1161	-1.2301	1.4248	-1.6030	-0.1782	-0.3729	1.0519
AFM	-0.3788	-1.2249	0.4815	-0.3645	0.5518	1.1924	-1.2566	-0.0642	-1.8084	-0.6160
AHSG	1.1795		-0.5545							
AMBP	0.6562	-0.3433	0.8607	-0.1389	-0.9023		1.2038		2.1061	
APCS	0.1498	0.2109	-0.0114	0.0497		0.3557			-0.0495	0.3063
APOA1	-0.1817	-0.6924	-0.2338	-0.7444	-0.7677	0.6941	-1.3173	-0.6232	-0.5496	0.1446
APOA2	0.0900	-1.1461	-0.6668	-1.9029						
APOA4	0.1296	0.9637	-1.2313	-0.3972	-1.3254	0.7876	-1.3347	-0.5471	-0.0093	0.7783
APOB	0.1379	-0.0164	-0.6333	-0.7876	-0.8570	0.5260	-1.2346	-0.7086	-0.3775	0.1485
APOE	-1.2134	0.2931	-0.6884	0.8180	-0.9078	0.7747	-1.5477	-0.7731	-0.6399	0.1347
APOH	-0.3602	-0.7025	-0.6445	-0.9867	-0.9997	2.8144	-1.0092	1.8052	-0.0095	2.8048
APOL1	-1.1791	-0.5194	-1.0440	-0.3843	-0.1153	0.5653	0.1299	0.6952	0.2452	0.8105
APOM	-1.2168	-0.6820	0.6935	1.2283		0.6562			0.6665	1.3227
ATRN			-1.0063							
AZGP1	1.2192	1.0252	0.0811	-0.1129	-3.3890	-3.6441	0.3703	-3.2738	3.7592	0.1152
C1QB	-0.8410	-2.0020	0.7071	-0.4539	-1.9729	1.3563	-2.0066	-0.6503	-0.0337	1.3226
C1R	-0.4335	-0.7632	0.0366	-0.2931	-0.1467	0.7976	0.3564	1.1540	0.5032	1.3008
C1S	0.0295	-0.8194	0.1680	-0.6809						
C2					-2.5581	2.5641	-2.5953	-0.0312	-0.0372	2.5269
C3	-0.7441	-0.6969	0.0652	0.1124	-1.0731	1.2388	-2.1616	-0.9228	-1.0886	0.1503
C4BPA	-0.1810	-2.4455	1.6628	-0.6017	-1.2379	1.5490	-1.8449	-0.2959	-0.6070	0.9420
C5	-0.5448	-0.2031	0.9230	1.2647	-0.7200	1.2710	-1.6769	-0.4058	-0.9569	0.3142
C6	-1.3936	1.7817	-1.3097	1.8656	-3.0452	1.7642	-3.2550	-1.4908	-0.2098	1.5544
C7	-0.9642	0.8848	-0.7827	1.0663	0.9970	0.0709	-1.1136	-1.0428	-2.1107	-2.0398
C8A	-0.5118	0.2737	-0.7630	0.0224	-2.8108	0.1731	-2.1285	-1.9554	0.6823	0.8554
C8B	-2.1950	0.2789	-1.5955	0.8785	-1.8944	-0.4803	-0.9598	-1.4400	0.9346	0.4544
C8G			-1.6305							
C9	-2.2199	0.4534	-1.9250	0.7483	-0.7346	0.6496	-3.2424	-2.5928	-2.5078	-1.8583
CD5L	-0.9293	-0.6205	-0.7146	-0.4057	-2.4643	0.4483	-2.3260	-1.8778	0.1383	0.5865
CFH	-1.1240	0.7407	-1.6481	0.2166	-1.0359	0.1380	-1.3260	-1.1880	-0.2902	-0.1522
CFI		0.5360		1.2578						
CLU	-1.1959	-0.8682	-0.1722	0.1555	-1.3664	0.8252	-2.1976	-1.3724	-0.8312	-0.0060
CP	-0.3892	0.2565	-0.4537	0.1920	-0.6658	0.4235	-0.2696	0.1540	0.3962	0.8197
F12	0.4852	-0.9398	0.6703	-0.7547	-0.8534	0.5550	-1.3146	-0.7596	-0.4612	0.0938
F2	-0.7493	-0.7564	0.0983	0.0912	-0.5409	1.1677	-1.5476	-0.3799	-1.0067	0.1610
FCN3		0.9645								
FGA	-0.9591	-0.5109	0.4842	0.9324	-1.0156	1.0487	-1.4708	-0.4221	-0.4552	0.5934
FGB	-0.8339	-0.1254	0.0684	0.7770	-0.8343	1.0951	-1.4647	-0.3695	-0.6303	0.4648
FGG	-1.1433	-0.0247	-0.2978	0.8208	-0.7191	0.7607	-1.0780	-0.3173	-0.3589	0.4018
FN1	-0.2796	-0.3153	0.2899	0.2541	-0.5778	1.1463	-1.2551	-0.1088	-0.6773	0.4690
GC	-0.5583	0.4051	-0.7950	0.1684	-1.8700	-0.2961	-1.2641	-1.5602	0.6059	0.3098
GSN	0.0705	0.0479	-0.6710	-0.6935						
HABP2					-0.5367	1.4446	-0.7071	0.7375	-0.1704	1.2742
HP	-1.2469	0.5276	-0.3488	1.4257	-0.6394	0.9683	-1.2963	-0.3280	-0.6570	0.3114
HPX	-0.4105	-0.2881	-0.7115	-0.5891	-0.3598	0.9360	-1.1034	-0.1674	-0.7437	0.1924
HRG	0.5979	1.0673	0.0322	0.5015	-0.7301	0.6894	-0.8232	-0.1338	-0.0931	0.5963
IGHA1	1.7636	1.3477	0.3629	-0.0530	-2.0152	0.4328	-2.2081	-1.7753	-0.1929	0.2399
IGHD					-2.4500	0.4182	-3.4285	-3.0102	-0.9785	-0.5603
IGHG1	-0.0855	0.9292	-0.4963	0.5184	-0.0970	-1.8091	0.4814	-1.3277	0.5785	-1.2306

Table S2: OpenMS log₂ fold changes in the plasma proteome of SCI patients from iTRAQ experiments. 'Acute' and 'Subacute' samples collected within 2 week and approximately 3-months post-injury respectively. (continued)

gene	Acute AIS C improvers vs non-improvers	Subacute AIS C improvers vs non-improvers	AIS C improvers acute vs subacute	AIS C non-improvers acute vs subacute	AIS C improvers vs non-improvers	AIS A vs D	AIS C improvers vs A	AIS C improvers vs D	AIS C non-improvers vs A	AIS C non-improvers vs D
IGHG2	0.9720	0.3502	0.4608	-0.1611	-0.6249	-1.5107	0.2705	-1.2401	0.8955	-0.6152
IGHG3	-0.1942	1.4323	-0.9310	0.6955	-1.8544	-0.3927	-1.8870	-2.2798	-0.0327	-0.4254
IGHM	-0.6318	-0.8967	-0.4175	-0.6824	-1.1742	1.7916	-2.3509	-0.5593	-1.1767	0.6149
IGKC	-0.0697	0.0420	-0.1150	-0.0032	-1.1868	-0.2875	-1.1765	-1.4641	0.0103	-0.2772
IGKV3D-20					-0.3699	-0.0537	0.2115	0.1578	0.5814	0.5277
ITIH1	-0.9767	0.7057	-0.5212	1.1612	-0.6149	0.5496	-0.5039	0.0456	0.1110	0.6605
ITIH2	-0.3143	-0.5283	-0.2363	-0.4504	-0.7432	0.6757	-1.2137	-0.5379	-0.4705	0.2052
ITIH3	-0.5456	0.6139	0.3513	1.5108	-2.0564	1.2902	-1.8743	-0.5841	0.1821	1.4724
ITIH4	-0.0670	-0.2189	0.3809	0.2289	-1.0844	0.9773	-1.8198	-0.8425	-0.7355	0.2418
KLKB1		-2.2093		-0.2714						
KNG1	-0.6198	-0.0025	-0.0676	0.5497	-0.6644	0.8053	0.0312	0.8365	0.6956	1.5009
LRG1	-0.7988	0.2565	0.1402	1.1955	-0.9516	1.7018	-2.1951	-0.4933	-1.2435	0.4583
LUM	0.0832	0.6580	-1.2636	-0.6888						
ORM1	-0.1975	1.1178	-0.2240	1.0913	-1.9126	1.6761	-1.3026	0.3735	0.6100	2.2862
PGLYRP2										
PLG	-0.3680	0.0881	-0.8410	-0.3850	-1.0702	2.7112	-2.8493	-0.1381	-1.7792	0.9321
PROS1	-0.3301	0.0624	-0.7963	-0.4039	-0.5090	1.5350	-3.8745	-2.3396	-3.3656	-1.8306
RBP4	0.4506	0.4186	-0.0212	-0.0532	-4.0971	1.4352	-2.9877	-1.5525	1.1094	2.5446
SAA1	-2.7778	2.3464	-0.5152	4.6090	-1.3859	2.4855	-2.5594	-0.0739	-1.1735	1.3120
SERPINA1	0.6826	0.0482	1.7824	1.1481	-0.0999	-0.1559	-1.3635	-1.5194	-1.2636	-1.4195
SERPINA3	-0.7582	-0.1618	0.1837	0.7802	-0.7418	2.2311	-2.0353	0.1958	-1.2936	0.9375
SERPINA4	0.0099		-1.0180		-1.4474		-0.6572		0.7902	
SERPINA5			0.2757							
SERPINC1	-0.5553	-0.2339	-0.5421	-0.2207	-0.7720	1.1067	-1.3465	-0.2398	-0.5744	0.5322
SERPIND1	0.2536		0.0459		0.3050	2.3844	-1.6469	0.7375	-1.9519	0.4325
SERPING1	-1.1615	0.1192	-1.3511	-0.0705	-0.9302	1.0767	-1.0905	-0.0138	-0.1603	0.9164
TF	-0.2824	-0.1105	-0.4844	-0.3125	-0.7682	0.5876	-0.9946	-0.4070	-0.2264	0.3612
VTN	-0.6186	-0.0324	-0.2690	0.3172	-1.7235	1.4919	-2.1518	-0.6599	-0.4283	1.0636
VWF		1.0586		1.3918	-2.5663	0.5162	-1.9774	-1.4612	0.5889	1.1051

Table S3: OpenMS log₂ fold changes in the plasma proteome of SCI patients from label-free experiments. 'Acute' and 'Subacute' samples collected within 2 week and approximately 3-months post-injury respectively.

Protein	Acute A Vs Subacute D	Acute C Improvers Vs Subacute D	Acute C Improvers Vs Subacute A	Acute C Non-Improvers Vs Subacute A	Acute A Vs Acute C Improvers	Acute A Vs Subacute C Non-Improvers	Acute A Vs Subacute A	Acute A Vs Subacute C Improvers	Acute C Non-Improvers Vs Subacute D
AFM		-0.7786		-1.1371					-1.3604
AHSG		-2.7643	-3.4309	-3.3017			-1.9761		
APOA4	-1.0588					-1.2657		-1.1544	
APOC3					-1.4275	-1.6878			
APOH		-1.3700							-1.5614
APOL1							-0.8923		
AQR								0.6965	
C4BPA		1.2058							
C4BPB		1.3009						1.3841	
C8G		-1.2253	-1.0543		1.1118				
C9	1.4444	1.0533				1.0217		1.2553	1.3765
CFH	0.5112	0.5790							
CFHR1		0.9812						1.4700	
CFHR5	1.3097								
CLEC3B	-1.9123	-1.5100				-1.4447		-1.3585	-1.6640
COMP		-2.2269	-2.8311	-2.3546			-2.4495		
CRP	4.0520					3.8525			3.3381
ECM1		-1.8865							
F10		1.1353							
F13A1	-2.0331	-1.9770	-1.9454			-1.8768	-2.0015	-2.0606	
F2		1.0044	0.8140						
F7					-0.7634				
F9		1.0227							
FCN3						-1.1449		-0.9483	
FGA	1.0806	0.7180				1.0275		0.7479	1.0928
FGB	0.7119	0.5186		0.7340		0.7738		0.5500	0.9761
FGL1	2.5544					2.5246		2.4956	
GPLD1					-1.4430				
GPX3	0.8877	0.7335							
HABP2	0.9940	1.1355							
HRG	-0.6336								
HYI							-1.0768		
IGHG2		-1.8011							
IGHG4			-2.2253	-2.6735					
IGLV3-19			-1.9672						
ITIH1						-1.0172			
ITIH4	1.9473	3.9089	0.8010	0.8216			0.8095	1.3021	1.4555
LBP	2.0666					1.6765	1.7122	1.8745	1.6204
LGALS3BP			1.9633						
LUM	-1.3539	-1.2002	-1.2800	-1.4246		-1.6006	-1.4338	-1.1914	-1.3447
LYZ				1.2935					
MASP1		0.9681			-1.0112				
MASP2		0.9549	0.9501						
ORM1		-1.2827			1.2451				
PCOLCE	-1.9201				-1.7506				
PGLYRP2	-1.2799	-0.9299	-1.1251	-1.4588		-1.4051	-1.4751	-1.2655	-1.2637
PLG		0.3879						0.3532	
PRG4	1.8915	1.9399	1.7628			1.4891	1.7144	1.3478	
RNASE4			4.3884				3.9924		
SAA1	5.4086					4.5431		3.6939	4.3015

Table S3: OpenMS log₂ fold changes in the plasma proteome of SCI patients from label-free experiments. 'Acute' and 'Subacute' samples collected within 2 week and approximately 3-months post-injury respectively. (continued)

Protein	Acute A Vs Subacute D	Acute C Improvers Vs Subacute D	Acute C Improvers Vs Subacute A	Acute C Non-Improvers Vs Subacute A	Acute A Vs Acute C Improvers	Acute A Vs Subacute C Non-Improvers	Acute A Vs Subacute A	Acute A Vs Subacute C Improvers	Acute C Non-Improvers Vs Subacute D
SAA2					4.4465				
SERPINA10		0.9102							
SERPINA4	-1.8496	-1.2216		-1.3820		-1.9414	-1.5613	-1.3615	-1.6703
SERPINF1	-1.1883								
THBS1			2.8162						
Trypsin		-0.5747							
VTN		0.7175	0.6959					0.7629	

Table S4: OpenMS log₂ fold changes in the plasma proteome of SCI patients from label-free experiments. 'Acute' and 'Subacute' samples collected within 2 week and approximately 3-months post-injury respectively.

Protein	Acute D Vs Subacute A	Acute C Improvers Vs Subacute C Improvers	Acute C Non-Improvers Vs Subacute C Non-Improvers	Acute C Non-Improvers Vs Subacute C Improvers	Acute D Vs Subacute D	Acute A Vs Acute D	Acute C Improvers Vs Subacute C Non-Improvers	Acute D Vs Subacute C Improvers	Acute D Vs Subacute C Non-Improvers
AFM			-1.216	-1.0952					
AHSG	-2.441								
APOH					-1.754				
C1QA				1.4061					
C4BPA		1.1610							
C4BPB		1.7228							
C9		0.8642		1.1875					
CFHR1		1.5119		1.5921					
COMP	-3.071								
CRP			3.139						
F13A1		-2.0045							
F2		1.0382							
F9		0.9526							
FGA			1.040						
FGB			1.038	0.8142					
FGL1						2.371			
GPLD1						-1.266			
HABP2		1.0118							
IGLV3-19	-2.495								
ITIH4					1.356				
LUM	-1.280	-1.0377	-1.591	-1.1822	-1.200		-1.447	-1.038	-1.447
PGLYRP2		-0.9155	-1.389	-1.2493					
PLG		0.4401							
PRG4		1.3963							
RNASE4	4.339								
SERPINA4			-1.762			-1.245			
VTN		0.9532		0.7628					

References

- 397
398 Anthony, Daniel C., and Yvonne Couch. 2014. “The Systemic Response to CNS Injury.” *Experimental*
399 *Neurology*, Special Issue: Neuroimmunology of spinal cord injury, 258 (August): 105–11. [https://doi.org/](https://doi.org/10.1016/j.expneurol.2014.03.013)
400 [10.1016/j.expneurol.2014.03.013](https://doi.org/10.1016/j.expneurol.2014.03.013).
- 401 Balmer, James E., and Rune Blomhoff. 2002. “Gene Expression Regulation by Retinoic Acid.” *Journal of*
402 *Lipid Research* 43 (11): 1773–1808. <https://doi.org/10.1194/jlr.R100015-JLR200>.
- 403 Bao, Feng, Vanessa Omana, Arthur Brown, and Lynne C. Weaver. 2012. “The Systemic Inflammatory
404 Response After Spinal Cord Injury in the Rat Is Decreased by a4B1 Integrin Blockade.” *Journal of*
405 *Neurotrauma* 29 (8): 1626–37. <https://doi.org/10.1089/neu.2011.2190>.
- 406 Bernardo Harrington, Gabriel Mateus, Paul Cool, Charlotte Hulme, Aheed Osman, Joy Chowdhury, Naveen
407 Kumar, Srinivasa Budithi, and Karina Wright. 2020. “Routinely Measured Haematological Markers
408 Can Help to Predict AIS Scores Following Spinal Cord Injury.” *Journal of Neurotrauma*, July. <https://doi.org/10.1089/neu.2020.7144>.
- 409
410 Boschetti, Egisto, and Pier Giorgio Righetti. 2008. “The ProteoMiner in the Proteomic Arena: A Non-
411 Depleting Tool for Discovering Low-Abundance Species.” *Journal of Proteomics*, Proteomic Technologies,
412 71 (3): 255–64. <https://doi.org/10.1016/j.jprot.2008.05.002>.
- 413 Brown, Sharon J., Gabriel M. B. Harrington, Charlotte H. Hulme, Rachel Morris, Anna Bennett, Wai-Hung
414 Tsang, Aheed Osman, Joy Chowdhury, Naveen Kumar, and Karina T. Wright. 2019. “A Preliminary
415 Cohort Study Assessing Routine Blood Analyte Levels and Neurological Outcome After Spinal Cord
416 Injury.” *Journal of Neurotrauma*, July. <https://doi.org/10.1089/neu.2019.6495>.
- 417 Campbell, Sandra J., Daniel C. Anthony, Fiona Oakley, Harald Carlsen, Ahmed M. Elsharkawy, Rune
418 Blomhoff, and Derek A. Mann. 2008. “Hepatic Nuclear Factor kB Regulates Neutrophil Recruitment
419 to the Injured Brain.” *Journal of Neuropathology & Experimental Neurology* 67 (3): 223–30. <https://doi.org/10.1097/NEN.0b013e3181654957>.
- 420
421 Campbell, Sandra J., V. Hugh Perry, Fernando J. Pitossi, Angus G. Butchart, Mariela Chertoff, Sara Waters,
422 Robert Dempster, and Daniel C. Anthony. 2005. “Central Nervous System Injury Triggers Hepatic CC
423 and CXC Chemokine Expression That Is Associated with Leukocyte Mobilization and Recruitment to
424 Both the Central Nervous System and the Liver.” *The American Journal of Pathology* 166 (5): 1487–97.
425 [https://doi.org/10.1016/S0002-9440\(10\)62365-6](https://doi.org/10.1016/S0002-9440(10)62365-6).
- 426 Campbell, Sandra J., Imran Zahid, Patrick Losey, Shing Law, Yanyan Jiang, Mehmet Bilgen, Nico van Rooijen,
427 Damineh Morsali, Andrew E. M. Davis, and Daniel C. Anthony. 2008. “Liver Kupffer Cells Control the
428 Magnitude of the Inflammatory Response in the Injured Brain and Spinal Cord.” *Neuropharmacology* 55
429 (5): 780–87. <https://doi.org/10.1016/j.neuropharm.2008.06.074>.
- 430 Chambers, Matthew C., Brendan Maclean, Robert Burke, Dario Amodei, Daniel L. Ruderman, Steffen
431 Neumann, Laurent Gatto, et al. 2012. “A Cross-Platform Toolkit for Mass Spectrometry and Proteomics.”
432 *Nature Biotechnology* 30 (10): 918–20. <https://doi.org/10.1038/nbt.2377>.
- 433 Choi, Meena, Ching-Yun Chang, Timothy Clough, Daniel Broudy, Trevor Killeen, Brendan MacLean, and
434 Olga Vitek. 2014. “MSstats: An R Package for Statistical Analysis of Quantitative Mass Spectrometry-
435 Based Proteomic Experiments.” *Bioinformatics* 30 (17): 2524–26. [https://doi.org/10.1093/bioinformatics](https://doi.org/10.1093/bioinformatics/btu305)
436 [/btu305](https://doi.org/10.1093/bioinformatics/btu305).
- 437 Chow, Diana S. L., Yang Teng, Elizabeth G. Toups, Bizhan Aarabi, James S. Harrop, Christopher I. Shaffrey,
438 Michele M. Johnson, et al. 2012. “Pharmacology of Riluzole in Acute Spinal Cord Injury.” *Journal of*
439 *Neurosurgery: Spine* 17 (Suppl1): 129–40. <https://doi.org/10.3171/2012.5.AOSPINE12112>.
- 440 Colbert, Melissa C., William W. Rubin, Elwood Linney, and Anthony-Samuel LaMantia. 1995. “Retinoid
441 signaling and the generation of regional and cellular diversity in the embryonic mouse spinal cord.”
442 *Developmental Dynamics* 204 (1): 1–12. <https://doi.org/10.1002/aja.1002040102>.
- 443 Crispe, Ian N. 2016. “Hepatocytes as Immunological Agents.” *The Journal of Immunology* 196 (1): 17–21.
444 <https://doi.org/10.4049/jimmunol.1501668>.
- 445 Crozier-Shaw, Geoff, Hazel Denton, and Seamus Morris. 2020. “Management Strategies in Acute Traumatic
446 Spinal Cord Injury: A Narrative Review.” *Neuroimmunology and Neuroinflammation* 7 (September).
447 <https://doi.org/10.20517/2347-8659.2019.005>.
- 448 DeLeve, Laurie D. 2007. “Hepatic Microvasculature in Liver Injury.” *Seminars in Liver Disease* 27 (04):
449 390–400. <https://doi.org/10.1055/s-2007-991515>.
- 450 Eng, Jimmy K., Tahmina A. Jahan, and Michael R. Hoopmann. 2013. “Comet: An Open-Source MS/MS

- 451 Sequence Database Search Tool.” *PROTEOMICS* 13 (1): 22–24. <https://doi.org/10.1002/pmic.201200439>.
- 452 Farkas, Gary J., and David R. Gater. 2018. “Neurogenic Obesity and Systemic Inflammation Following
453 Spinal Cord Injury: A Review.” *The Journal of Spinal Cord Medicine* 41 (4): 378–87. <https://doi.org/10.1080/10790268.2017.1357104>.
- 454
- 455 Fleming, Jennifer C., Christopher S. Bailey, Hans Hundt, Kevin R. Gurr, Stewart I. Bailey, Gediminas
456 Cepinskas, Abdel-rahman Lawendy, and Amit Badhwar. 2012. “Remote Inflammatory Response in Liver
457 Is Dependent on the Segmental Level of Spinal Cord Injury.” *Journal of Trauma and Acute Care Surgery*
458 72 (5): 1194–1201. <https://doi.org/10.1097/ta.0b013e31824d68bd>.
- 459 Frost, Frederick, Mary Jo Roach, Irving Kushner, and Peter Schreiber. 2005. “Inflammatory C-reactive
460 Protein and Cytokine Levels in Asymptomatic People with Chronic Spinal Cord Injury.” *Archives of*
461 *Physical Medicine and Rehabilitation* 86 (2): 312–17. <https://doi.org/10.1016/j.apmr.2004.02.009>.
- 462 Fuller, Heidi R., Robert Slade, Nataša Jovanov-Milošević, Mirjana Babić, Goran Sedmak, Goran Šimić,
463 Matthew A. Fuszard, Sally L. Shirran, Catherine H. Botting, and Monte A. Gates. 2015. “Stathmin Is
464 Enriched in the Developing Corticospinal Tract.” *Molecular and Cellular Neuroscience* 69 (November):
465 12–21. <https://doi.org/10.1016/j.mcn.2015.09.003>.
- 466 Furlan, Julio C, Sivakumar Gulasingam, and B Catharine Craven. 2017. “The Health Economics of the
467 Spinal Cord Injury or Disease Among Veterans of War : A Systematic Review.” *The Journal of Spinal*
468 *Cord Medicine* 40 (6): 649–64. <https://doi.org/10.1080/10790268.2017.1368267>.
- 469 Gan, Yu, Xunming Ji, Xiaoming Hu, Yumin Luo, Lili Zhang, Peiyong Li, Xiangrong Liu, et al. 2012.
470 “Transgenic Overexpression of Peroxiredoxin-2 Attenuates Ischemic Neuronal Injury Via Suppression
471 of a Redox-Sensitive Pro-Death Signaling Pathway.” *Antioxidants & Redox Signaling* 17 (5): 719–32.
472 <https://doi.org/10.1089/ars.2011.4298>.
- 473 Garcia-Bonilla, Lidia, and Costantino Iadecola. 2012. “Peroxiredoxin Sets the Brain on Fire After Stroke.”
474 *Nature Medicine* 18 (6): 858–59. <https://doi.org/10.1038/nm.2797>.
- 475 García-López, P., A. Martínez-Cruz, G. Guízar-Sahagún, and G. Castañeda-Hernández. 2007. “Acute Spinal
476 Cord Injury Changes the Disposition of Some, but Not All Drugs Given Intravenously.” *Spinal Cord* 45
477 (9): 603–8. <https://doi.org/10.1038/sj.sc.3102001>.
- 478 Goodus, Matthew T., Andrew D. Sauerbeck, Phillip G. Popovich, Richard S. Bruno, and Dana M. McTigue.
479 2018. “Dietary Green Tea Extract Prior to Spinal Cord Injury Prevents Hepatic Iron Overload but Does
480 Not Improve Chronic Hepatic and Spinal Cord Pathology in Rats.” *Journal of Neurotrauma* 35 (24):
481 2872–82. <https://doi.org/10.1089/neu.2018.5771>.
- 482 Gris, Denis, Eilis F. Hamilton, and Lynne C. Weaver. 2008. “The Systemic Inflammatory Response
483 After Spinal Cord Injury Damages Lungs and Kidneys.” *Experimental Neurology* 211 (1): 259–70.
484 <https://doi.org/10.1016/J.EXPNEUROL.2008.01.033>.
- 485 Guo, Qiang, Shurong Li, Yajie Liang, Yanling Zhang, Jiqiang Zhang, Can Wen, Sen Lin, Hanzhi Wang, and
486 Bingyin Su. 2010. “Effects of C3 Deficiency on Inflammation and Regeneration Following Spinal Cord
487 Injury in Mice.” *Neuroscience Letters* 485 (1): 32–36. <https://doi.org/10.1016/j.neulet.2010.08.056>.
- 488 Hagen, Ellen Merete. 2015. “Acute Complications of Spinal Cord Injuries.” *World Journal of Orthopedics* 6
489 (1): 17–23. <https://doi.org/10.5312/wjo.v6.i1.17>.
- 490 Haskell, Gloria Thompson, Thomas Michael Maynard, Ron Andrew Shatzmiller, and Anthony-Samuel
491 Lamantia. 2002. “Retinoic Acid Signaling at Sites of Plasticity in the Mature Central Nervous System.”
492 *Journal of Comparative Neurology* 452 (3): 228–41. <https://doi.org/10.1002/cne.10369>.
- 493 Hayes, K.c., T.c.l. Hull, G.a. Delaney, P.j. Potter, K.a.j. Sequeira, K. Campbell, and P.g. Popovich. 2002.
494 “Elevated Serum Titers of Proinflammatory Cytokines and CNS Autoantibodies in Patients with Chronic
495 Spinal Cord Injury.” *Journal of Neurotrauma* 19 (6): 753–61. <https://doi.org/10.1089/08977150260139129>.
- 496 Hulme, C. H., S. J. Brown, H. R. Fuller, J. Riddell, A. Osman, J. Chowdhury, N. Kumar, W. E. Johnson,
497 and K. T. Wright. 2017. “The Developing Landscape of Diagnostic and Prognostic Biomarkers for Spinal
498 Cord Injury in Cerebrospinal Fluid and Blood.” *Spinal Cord* 55 (2): 114–25. <https://doi.org/10.1038/sc.2016.174>.
- 499
- 500 Hulstaert, Niels, Jim Shofstahl, Timo Sachsenberg, Mathias Walzer, Harald Barsnes, Lennart Martens, and
501 Yasset Perez-Riverol. 2020. “ThermoRawFileParser: Modular, Scalable, and Cross-Platform RAW File
502 Conversion.” *Journal of Proteome Research* 19 (1): 537–42. <https://doi.org/10.1021/acs.jproteome.9b00328>.
- 503 328.
- 504 Hundt, H., J. C. Fleming, J. T. Phillips, A. Lawendy, K. R. Gurr, S. I. Bailey, D. Sanders, et al. 2011.

- 505 “Assessment of Hepatic Inflammation After Spinal Cord Injury Using Intravital Microscopy.” *Injury* 42
506 (7): 691–96. <https://doi.org/10.1016/j.injury.2010.12.013>.
- 507 Hurst, Robert E., Przemyslaw Waliszewski, Mirosława Waliszewska, Rebecca B. Bonner, Doris M. Benbrook,
508 Arindam Dar, and George P. Hemstreet. 1999. “Complexity, Retinoid-Responsive Gene Networks, and
509 Bladder Carcinogenesis.” In *Advances in Bladder Research*, edited by Laurence S. Baskin and Simon
510 W. Hayward, 462:449–67. *Advances in Experimental Medicine and Biology*. Boston, MA: Springer US.
511 https://doi.org/10.1007/978-1-4615-4737-2_35.
- 512 Jassal, Bijay, Lisa Matthews, Guilherme Viteri, Chuqiao Gong, Pascual Lorente, Antonio Fabregat, Kon-
513 stantinos Sidiropoulos, et al. 2020. “The Reactome Pathway Knowledgebase.” *Nucleic Acids Research* 48
514 (D1): D498–503. <https://doi.org/10.1093/nar/gkz1031>.
- 515 Jogia, Trisha, Marcel A. Kopp, Jan M. Schwab, and Marc J. Ruitenber. 2021. “Peripheral White Blood Cell
516 Responses as Emerging Biomarkers for Patient Stratification and Prognosis in Acute Spinal Cord Injury.”
517 *Current Opinion in Neurology* 34 (6): 796–803. <https://doi.org/10.1097/WCO.0000000000000995>.
- 518 Kim, So Yong, Tae Jin Kim, and Ki-Young Lee. 2008. “A Novel Function of Peroxiredoxin 1 (Prx-1) in
519 Apoptosis Signal-Regulating Kinase 1 (ASK1)-Mediated Signaling Pathway.” *FEBS Letters* 582 (13):
520 1913–18. <https://doi.org/10.1016/j.febslet.2008.05.015>.
- 521 Kwon, Brian K., Ona Bloom, Ina-Beate Wanner, Armin Curt, Jan M. Schwab, James Fawcett, and Kevin
522 K. Wang. 2019. “Neurochemical Biomarkers in Spinal Cord Injury.” *Spinal Cord* 57 (10): 819–31.
523 <https://doi.org/10.1038/s41393-019-0319-8>.
- 524 Kwon, Brian K., Anthea M T Stammers, Lise M Belanger, Arlene Bernardo, Donna Chan, Carole M
525 Bishop, Gerard P Slobogean, et al. 2010. “Cerebrospinal Fluid Inflammatory Cytokines and Biomarkers
526 of Injury Severity in Acute Human Spinal Cord Injury.” *Journal of Neurotrauma* 27 (4): 669–82.
527 <https://doi.org/10.1089/neu.2009.1080>.
- 528 Lane, Michelle A., and Sarah J. Bailey. 2005. “Role of Retinoid Signalling in the Adult Brain.” *Progress in*
529 *Neurobiology* 75 (4): 275–93. <https://doi.org/10.1016/j.pneurobio.2005.03.002>.
- 530 Low, Felicia M., Mark B. Hampton, and Christine C. Winterbourn. 2008. “Peroxiredoxin 2 and Peroxide
531 Metabolism in the Erythrocyte.” *Antioxidants & Redox Signaling* 10 (9): 1621–30. <https://doi.org/10.1089/ars.2008.2081>.
- 532
- 533 Lu, Yue, Xiang-Sheng Zhang, Zi-Huan Zhang, Xiao-Ming Zhou, Yong-Yue Gao, Guang-Jie Liu, Han Wang,
534 Ling-Yun Wu, Wei Li, and Chun-Hua Hang. 2018. “Peroxiredoxin 2 Activates Microglia by Interacting
535 with Toll-like Receptor 4 After Subarachnoid Hemorrhage.” *Journal of Neuroinflammation* 15 (1): 87.
536 <https://doi.org/10.1186/s12974-018-1118-4>.
- 537 Lu, Yue, Xiang-Sheng Zhang, Xiao-Ming Zhou, Yong-Yue Gao, Chun-Lei Chen, Jing-Peng Liu, Zhen-Nan Ye,
538 et al. 2019. “Peroxiredoxin 1/2 Protects Brain Against H₂O₂-induced Apoptosis After Subarachnoid
539 Hemorrhage.” *The FASEB Journal* 33 (2): 3051–62. <https://doi.org/10.1096/fj.201801150R>.
- 540 Malaspina, Andrea, Narendra Kaushik, and Jackie De Bellerocche. 2001. “Differential Expression of 14
541 Genes in Amyotrophic Lateral Sclerosis Spinal Cord Detected Using Gridded cDNA Arrays.” *Journal of*
542 *Neurochemistry* 77 (1): 132–45. <https://doi.org/10.1046/j.1471-4159.2001.00231.x>.
- 543 Matsuzawa, Atsushi, Kaoru Saegusa, Takuya Noguchi, Chiharu Sadamitsu, Hideki Nishitoh, Shigenori Nagai,
544 Shigeo Koyasu, Kunihiro Matsumoto, Kohsuke Takeda, and Hidenori Ichijo. 2005. “ROS-dependent
545 Activation of the TRAF6-ASK1-p38 Pathway Is Selectively Required for TLR4-mediated Innate Immunity.”
546 *Nature Immunology* 6 (6): 587–92. <https://doi.org/10.1038/ni1200>.
- 547 McDaid, David, A.-La Park, Angela Gall, Mariel Purcell, and Mark Bacon. 2019. “Understanding and
548 Modelling the Economic Impact of Spinal Cord Injuries in the United Kingdom.” *Spinal Cord* 57 (9):
549 778–88. <https://doi.org/10.1038/s41393-019-0285-1>.
- 550 Peffers, M. J., B. McDermott, P. D. Clegg, and C. M. Riggs. 2015. “Comprehensive Protein Profiling of
551 Synovial Fluid in Osteoarthritis Following Protein Equalization.” *Osteoarthritis and Cartilage* 23 (7):
552 1204–13. <https://doi.org/10.1016/j.joca.2015.03.019>.
- 553 Perez-Riverol, Yasset, Jingwen Bai, Chakradhar Bandla, David García-Seisdedos, Suresh Hewapathirana,
554 Selvakumar Kamatchinathan, Deepti J Kundu, et al. 2021. “The PRIDE Database Resources in 2022: A
555 Hub for Mass Spectrometry-Based Proteomics Evidences.” *Nucleic Acids Research* 50 (D1): D543–52.
556 <https://doi.org/10.1093/nar/gkab1038>.
- 557 Peterson, P. A. 1971. “Studies on the Interaction Between Prealbumin, Retinol-Binding Protein, and Vitamin
558 A.” *The Journal of Biological Chemistry* 246 (1): 44–49.

- 559 Qiao, Fei, Carl Atkinson, Hongbin Song, Ravinder Pannu, Inderjit Singh, and Stephen Tomlinson. 2006.
560 “Complement Plays an Important Role in Spinal Cord Injury and Represents a Therapeutic Target
561 for Improving Recovery Following Trauma.” *The American Journal of Pathology* 169 (3): 1039–47.
562 <https://doi.org/10.2353/ajpath.2006.060248>.
- 563 Rhee, Sue Goo, and Hyun Ae Woo. 2011. “Multiple Functions of Peroxiredoxins: Peroxidases, Sensors
564 and Regulators of the Intracellular Messenger H₂O₂, and Protein Chaperones.” *Antioxidants & Redox
565 Signaling* 15 (3): 781–94. <https://doi.org/10.1089/ars.2010.3393>.
- 566 Röst, Hannes L., Timo Sachsenberg, Stephan Aiche, Chris Bielow, Hendrik Weisser, Fabian Aicheler, Sandro
567 Andreotti, et al. 2016. “OpenMS: A Flexible Open-Source Software Platform for Mass Spectrometry
568 Data Analysis.” *Nature Methods* 13 (9): 741–48. <https://doi.org/10.1038/nmeth.3959>.
- 569 Salzano, Sonia, Paola Checconi, Eva-Maria Hanschmann, Christopher Horst Lillig, Lucas D. Bowler, Philippe
570 Chan, David Vaudry, et al. 2014. “Linkage of Inflammation and Oxidative Stress via Release of
571 Glutathionylated Peroxiredoxin-2, Which Acts as a Danger Signal.” *Proceedings of the National Academy
572 of Sciences* 111 (33): 12157–62. <https://doi.org/10.1073/pnas.1401712111>.
- 573 Sauerbeck, Andrew D., J. Lukas Laws, Veera V. R. Bandaru, Phillip G. Popovich, Norman J. Haughey, and
574 Dana M. McTigue. 2014. “Spinal Cord Injury Causes Chronic Liver Pathology in Rats.” *Journal of
575 Neurotrauma* 32 (3): 159–69. <https://doi.org/10.1089/neu.2014.3497>.
- 576 Segal, J. L., E. Gonzales, S. Yousefi, L. Jamshidipour, and S. R. Brunnemann. 1997. “Circulating Levels of
577 IL-2R, ICAM-1, and IL-6 in Spinal Cord Injuries.” *Archives of Physical Medicine and Rehabilitation* 78
578 (1): 44–47. [https://doi.org/10.1016/s0003-9993\(97\)90008-3](https://doi.org/10.1016/s0003-9993(97)90008-3).
- 579 Shichita, Takashi, Eiichi Hasegawa, Akihiro Kimura, Rimpei Morita, Ryota Sakaguchi, Ichiro Takada, Takashi
580 Sekiya, et al. 2012. “Peroxiredoxin Family Proteins Are Key Initiators of Post-Ischemic Inflammation in
581 the Brain.” *Nature Medicine* 18 (6): 911–17. <https://doi.org/10.1038/nm.2749>.
- 582 Sockanathan, Shanthini, and Thomas M Jessell. 1998. “Motor Neuron-Derived Retinoid Signaling Specifies
583 the Subtype Identity of Spinal Motor Neurons.” *Cell* 94 (4): 503–14. [https://doi.org/10.1016/S0092-8674\(00\)81591-3](https://doi.org/10.1016/S0092-8674(00)81591-3).
- 585 Song, Guoqing, Cate Cechvala, Daniel K. Resnick, Robert J. Dempsey, and Vemuganti L. Raghavendra Rao.
586 2001. “GeneChip Analysis After Acute Spinal Cord Injury in Rat.” *Journal of Neurochemistry* 79 (4):
587 804–15. <https://doi.org/10.1046/j.1471-4159.2001.00626.x>.
- 588 Spiess, Martina R., Roland M. Müller, Rüdiger Rupp, Christian Schuld, and Hubertus J. A. van Hedel.
589 2009. “Conversion in ASIA Impairment Scale During the First Year After Traumatic Spinal Cord Injury.”
590 *Journal of Neurotrauma* 26 (11): 2027–36. <https://doi.org/10.1089/neu.2008.0760>.
- 591 Stoscheck, Christa M. 1987. “Protein Assay Sensitive at Nanogram Levels.” *Analytical Biochemistry* 160 (2):
592 301–5. [https://doi.org/10.1016/0003-2697\(87\)90051-0](https://doi.org/10.1016/0003-2697(87)90051-0).
- 593 Sun, Xin, Zachary B. Jones, Xiao-ming Chen, Libing Zhou, Kwok-Fai So, and Yi Ren. 2016. “Multiple Organ
594 Dysfunction and Systemic Inflammation After Spinal Cord Injury: A Complex Relationship.” *Journal of
595 Neuroinflammation* 13 (1): 260. <https://doi.org/10.1186/s12974-016-0736-y>.
- 596 Szalai, Alexander J., Frederik W. van Ginkel, Yue Wang, Jerry R. McGhee, and John E. Volanakis. 2000.
597 “Complement-Dependent Acute-Phase Expression of C-Reactive Protein and Serum Amyloid P-Component.”
598 *The Journal of Immunology* 165 (2): 1030–35. <https://doi.org/10.4049/jimmunol.165.2.1030>.
- 599 The UniProt Consortium. 2021. “UniProt: The Universal Protein Knowledgebase in 2021.” *Nucleic Acids
600 Research* 49 (D1): D480–89. <https://doi.org/10.1093/nar/gkaa1100>.
- 601 Wang, Kevin K., Zhihui Yang, Tian Zhu, Yuan Shi, Richard Rubenstein, J. Adrian Tyndall, and Geoff T.
602 Manley. 2018. “An Update on Diagnostic and Prognostic Biomarkers for Traumatic Brain Injury.” *Expert
603 Review of Molecular Diagnostics* 18 (2): 165–80. <https://doi.org/10.1080/14737159.2018.1428089>.
- 604 Yang, Chih-Ya, Jiun-Bo Chen, Ting-Fen Tsai, Yi-Chen Tsai, Ching-Yen Tsai, Pi-Hui Liang, Tsui-Ling
605 Hsu, et al. 2013. “CLEC4F Is an Inducible C-Type Lectin in F4/80-Positive Cells and Is Involved in
606 Alpha-Galactosylceramide Presentation in Liver.” *PLOS ONE* 8 (6): e65070. [https://doi.org/10.1371/jo
607 urnal.pone.0065070](https://doi.org/10.1371/journal.pone.0065070).
- 608 Yu, Guangchuang, and Qing-Yu He. 2016. “ReactomePA: An R/Bioconductor Package for Reactome Pathway
609 Analysis and Visualization.” *Molecular BioSystems* 12 (2): 477–79. <https://doi.org/10.1039/c5mb00663e>.