

1
1
2
3
4
5
6
7
8
9
10
11
12
13
14
15
16
17
18
19
20
21
22
23
24
25

Genetic sensitivity analysis: adjusting for genetic confounding in epidemiological associations

Jean-Baptiste Pingault^{*1,2}, PhD; Frühling Rijsdijk², PhD; Tabea Schoeler¹, PhD; Shing Wan Choi^{2,3}, PhD; Saskia Selzam², MsC; Eva Krapohl², PhD; Paul F. O'Reilly^{2,3}, PhD; Frank Dudbridge⁴, PhD.

¹Department of Clinical, Educational and Health Psychology, University College London, London, UK.

²Social, Genetic, and Developmental Psychiatry, King's College London, London, UK.

³Department of Genetics and Genomic Sciences, Icahn School of Medicine, Mount Sinai

⁴Department of Health Sciences, University of Leicester, Leicester.

*Corresponding author: j.pingault@ucl.ac.uk (JBP)

2

Genetic confounding 2

26

Abstract

27 Associations between exposures and outcomes reported in epidemiological studies are typically
28 unadjusted for genetic confounding. We propose a two-stage approach for estimating the degree to
29 which such observed associations can be explained by genetic confounding. First, we assess attenuation
30 of exposure effects in regressions controlling for increasingly powerful polygenic scores. Second, we
31 use structural equation models to estimate genetic confounding using heritability estimates derived from
32 both SNP-based and twin-based studies. We examine associations between maternal education and three
33 developmental outcomes – child educational achievement, Body Mass Index, and Attention Deficit
34 Hyperactivity Disorder. Polygenic scores explain between 14.3% and 23.0% of the original associations,
35 while analyses under SNP- and twin-based heritability scenarios indicate that observed associations
36 could be almost entirely explained by genetic confounding. Thus, caution is needed when interpreting
37 associations from non-genetically informed epidemiology studies. Our approach, akin to a genetically
38 informed sensitivity analysis can be applied widely.

39

Author summary

40 An objective shared across the life, behavioural, and social sciences is to identify factors that increase
41 risk for a particular disease or trait. However, identifying true risk factors is challenging. Often, a risk
42 factor is statistically associated with a disease even if it is not really relevant, meaning that even
43 successfully improving the risk factor will not impact the disease. One reason for the existence of such
44 misleading associations stems from genetic confounding. This is when genetic factors influence both the
45 risk factor and the disease, which generates a statistical association even in the absence of a true effect
46 of the risk factor. Here, we propose a method to estimate genetic confounding and quantify its effect on
47 observed associations. We show that a large part of the associations between maternal education and
48 three child outcomes - educational achievement, body mass index and Attention-Deficit Hyperactivity
49 Disorder- is explained by genetic confounding. Our findings can be applied to better understand the role
50 of genetics in explaining associations of key risk factors with diseases and traits.

Introduction

52 Associations between exposures and outcomes are commonly reported in epidemiological research, but
53 often without estimating or accounting for the contribution from genetics. However, most exposures and
54 outcomes are substantially heritable, and genetics can confound these associations. Here, we propose a
55 new genetic sensitivity analysis, which we call *Gsens*, to assess to what extent genetic confounding can
56 account for observed associations.

58 *Genetic confounding and sensitivity analysis*

59 Identifying exposures that can be targeted in effective interventions is a fundamental objective shared
60 across the life, behavioural and social sciences. To this end, identifying *causal* exposures is essential as
61 interventions that target non-causal exposures will likely fail. To establish causation, it is necessary to
62 account for confounding, which happens when a third variable causally influences both the exposure
63 and the outcome, thereby generating a non-causal association between them. Genetic confounding is a
64 special case when genetic factors play the role of the third variable. The concept of genetic confounding
65 was introduced during the controversy regarding the effect of cigarette smoking on lung cancer. In a
66 letter entitled 'alleged dangers of cigarette-smoking', Ronald Fisher qualified 'the mild and soothing
67 weed' as 'possibly an entirely imaginary cause' for lung cancer [1]. He argued that genetic factors could
68 directly influence both smoking and lung cancer, generating a non-causal association between them.
69 Although Fisher was mistaken in this particular instance, the notion of genetic confounding remains
70 relevant, in his words 'a common cause, in this case the individual genotype'. During this controversy,
71 Jerome Cornfield argued against this 'constitutional hypothesis' [2,3]. He contended that implausibly
72 large genetic effects (or other unobserved confounders) would be required to explain away all of the
73 observed association. This led to the birth of the approach now called *sensitivity analysis*, which consists
74 of estimating how strong an unknown confounder needs to be in order to explain away an observed
75 association, providing insights into the robustness of that association (i.e. how sensitive it is to

confounding and whether it is likely causal or not) [2]. Since then, sensitivity analyses have become common epidemiological tools to probe the robustness of findings under alternative scenarios. However, sensitivity analysis using genetic data has not progressed. We recently [4] proposed to use polygenic scores – individual-level scores that summarize genetic risk (or protection) for a given phenotype – to estimate the proportion of observed associations explained by genetic confounding. However, because polygenic scores capture only a small part of heritability, controlling for polygenic scores cannot entirely capture genetic confounding. We therefore propose a sensitivity analysis using polygenic scores to gauge how likely it is that genetic confounding accounts, in part or entirely, for a given exposure-outcome association. Here, we develop this proposition in two stages. First, we test to what extent associations of interest are accounted for by observed polygenic scores. Second, in the sensitivity analysis per se, we use structural equation models to examine how an increase in the predictive power of polygenic scores based on heritability estimates would affect association estimates. This can be thought of as adjusting for latent polygenic scores that capture as much of the variance in the exposure and outcome as suggested by available heritability estimates.

Maternal education and child developmental outcomes

To illustrate our approach, we focus on maternal educational attainment (termed maternal education) as the exposure of interest. Greater maternal education is associated with child developmental outcomes in several key domains: social development (e.g. better educational outcomes), physical health (e.g. lower Body Mass Index, BMI), and mental health (e.g. lower levels of Attention-Deficit Hyperactivity Disorder (ADHD) symptoms)[5–8]. However, observed associations between maternal education and developmental outcomes are not free from confounding, in particular genetic confounding as both maternal education and developmental outcomes are heritable, and mother and child share half their genomes identical by descent [5,9–13].

Here, we illustrate the use of *Gsens* to estimate the role of genetic confounding in explaining the

101 associations between maternal educational and three developmental outcomes in the child: educational
102 achievement operationalized by the General Certificate of Secondary Education (GCSE), BMI, and
103 ADHD. Importantly, *Gsens* has a wide scope of applications as it only requires genome-wide data on
104 large samples and a focus on outcomes for which polygenic scores are available. Its applicability will
105 further expand with the steady increase in the number and the accuracy of available polygenic scores
106 [14].

107 **Results**

108 ***Method Overview***

109 Participants were drawn from the Twins Early Development Study (TEDS), with sample sizes between
110 3,663 and 4,693 individuals with data for maternal education and child educational achievement, BMI,
111 and ADHD. Polygenic scores were estimated in the child using PRSice software [15] at different p-value
112 thresholds, explaining increasing amounts of variance in the corresponding phenotype. In the first stage,
113 we estimated the proportion of the observed phenotypic association between the exposure and the
114 outcome that was explained by polygenic scores at different p-value thresholds; we call these the
115 *observed scenarios*. However, even the best-fitting polygenic scores only captured a fraction of the
116 heritability of their corresponding phenotypes, thus underestimating the magnitude of genetic
117 confounding. In the second stage, the sensitivity analysis therefore aimed to answer the following
118 question: to what extent is the exposure X associated with the outcome Y after controlling for all genetic
119 confounding? In other words, if β_{XY} is the coefficient of regression of Y on X, to what extent would it
120 attenuate if we were to control for ‘perfect’ polygenic scores capturing all genetic influences on X and Y
121 rather than the small fraction accounted for by available polygenic scores? To this end, we estimated
122 β_{XY} under plausible scenarios combining information on current polygenic scores and heritability
123 estimates. The estimation of β_{XY} is based on the matrix of observed correlations between polygenic
124 scores, exposure and outcomes. We then fit a Structural Equation Model to this matrix of correlations
125 that aims to reflect the true extent of genetic confounding (see Methods). Approaches using one

polygenic score (for the exposure or for the outcome) or two polygenic scores (for the exposure and the outcome) were used. Three functions are provided that adjust the association of interest based on the polygenic score for the exposure (GsensX), for the outcome (GsensY) or both exposure and outcome (GsensXY). We conducted simulations to assess the relative accuracy of these functions and to assess the effect of unobserved non-genetic confounding on the estimates obtained from *Gsens*. We provide a package and a tutorial at <https://github.com/JBPG/Gsens>.

Observed and heritability-based scenarios

As shown in Table 1, the best-fitting polygenic scores derived from the GWAS for years of education, BMI and ADHD explained a substantial amount of the variance of, respectively, child educational achievement (threshold of $p = .158$), BMI (threshold: $p = .20$) and ADHD symptoms (threshold: $p = 0.358$) in TEDS. All three were highly significant (largest p value = $1.6e-20$ for ADHD). Table 1 shows parameters for two main heritability-based scenarios: SNP-based and Twin-based heritability. SNP-based heritability estimates were obtained through LD score regression [16,17], based on LD Hub [18] for years of education and BMI and the most recent ADHD GWAS for ADHD [13]. Twin-based estimates were derived from TEDS and from the literature (see Table 1 note).

Table 1. Heritability and genetic correlation under different scenarios

	Heritability (% variance)			Exposure-outcome genetic correlation	
	Education	BMI	ADHD	Education~ BMI	Education~ ADHD
Best-Fitting Polygenic score	11.9	6.3	1.3	-0.185	-0.184
SNP-based scenario	31.0	18.6	21.6	-0.279	-0.535
Twin scenario	63.0 ¹	64.0	62.0 ²	-0.045 ³	-0.444 ³

¹Heritability of the GCSE score estimated in TEDS was used. ²Twin estimates for ADHD in TEDS are superior to $> .80$ [5]. However, a twin meta-analysis has argued that commonly reported heritability estimates for ADHD may be biased, and estimated broad-sense heritability to be 62%, which is used here [19]. ³As maternal education attainment does not vary within family, it is not possible to directly estimate the twin-based genetic correlation between maternal educational and child BMI and ADHD in TEDS, so child GCSE was used as a proxy of educational attainment.

149 ***Genetic confounding and sensitivity analyses***

150 *Single polygenic score: child educational achievement*

151 Supplementary material S1 eTable 1 shows correlations between study variables. The observational
152 estimate of the relationship between maternal educational attainment and child GCSE was 0.398 (95%
153 CI: 0.368, 0.427). Using the best fitting polygenic score for years of education, the effect explained by
154 genetic confounding was estimated at 0.073 (0.067, 0.080), corresponding to 18.2% of the total effect.
155 After taking this genetic confounding effect (as captured by the polygenic score) into account, the
156 relationship between maternal education and child GCSE was reduced to 0.324 (0.291, 0.357).

157 The sensitivity analysis is represented in Figure 1, where standardized estimates of the effect of maternal
158 education on child GCSE are plotted as a function of the variance explained in the latter. We first re-
159 estimated the effect of maternal education on child GCSE by adjusting for observed polygenic scores at
160 different p value thresholds, explaining different amounts of variance in GCSE scores. We then
161 estimated the effect of maternal education on child GCSE under scenarios in which polygenic scores
162 could capture additional variance in educational outcomes (see Methods). The SNP-heritability
163 scenario is based on the SNP-heritability of GCSE scores, which was previously estimated in TEDS to
164 be 31% [10]. Under this scenario the effect of maternal education on child achievement further
165 decreased to 0.175 (0.129, 0.222). The effect estimate was null under the twin-heritability scenario.

166 We define k as the ratio of the standardized path from the polygenic score to the exposure divided by the
167 standardized path from the polygenic score to the outcome (see Methods). The estimated k was 0.84.

168 This is higher than the value of 0.5 expected when X and Y are the same trait measured in parents and
169 children (meaning that the standardized association between the child polygenic score and maternal
170 education should be, at most, half of the standardized association between the child polygenic score and
171 the child educational outcome). In addition to sample-specific findings, this could be because the
172 polygenic score for child educational achievement was derived from a GWAS of years of education in
173 adults, which is closer to the maternal education phenotype (X) than the child GCSE phenotype (Y). A

174 similar finding was observed by Bates et al. [20]. When setting $k = 0.5$ under the twin-heritability
175 scenario, the estimate of $\hat{\beta}_{XY}$ is still considerably reduced compared to the observed correlation but
176 remains positive at 0.098 (0.066, 0.129).

Figure 1. Gsens analysis of the effect of maternal educational attainment on child educational achievement

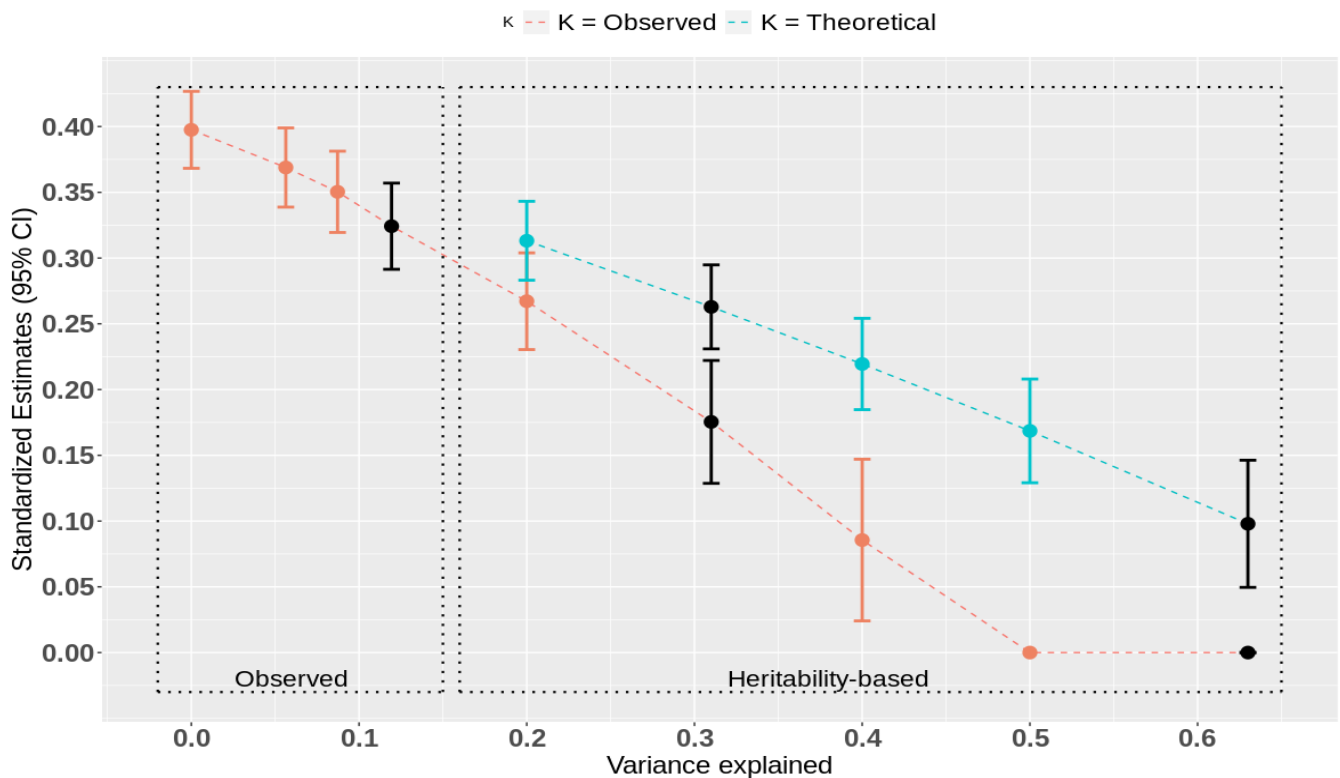

Caption. Estimated standardized effect of maternal education on child educational achievement (Y axis) after accounting for genetic confounding using observed polygenic scores and heritability-based scenarios explaining an increasing percentage of variance (X axis). Point estimates and confidence intervals in black represent main estimates of interest, after accounting for (from left to right): 1: the best-fitting polygenic score; 2: SNP-heritability of educational achievement as assessed by GCSE scores in TEDS; 3: twin-heritability of educational achievement. A lower bound of 0 was imposed on the estimate, which is reached for the twin estimate of heritability (63%). The line “ $k = \text{Observed}$ ” corresponds to heritability-based scenarios using values of model parameter k derived from observed polygenic scores (see Methods). “ $k = \text{theoretical}$ ” corresponds to the value of k when the same trait is in parents and children and the heritability is the same in parents and children. In this case $k=0.5$ (see Methods).

181 *Two polygenic scores: BMI and ADHD*

182 The observational estimate of the relationship between maternal education and child BMI was $\beta_{XY} = -$
 183 0.089 (-0.122, -0.057). Using the best fitting polygenic scores for years of education and BMI, the
 184 genetic confounding effect was estimated at -0.021 (-0.028, -0.013), corresponding to 23.0% of the total
 185 effect. After taking this genetic confounding effect into account, the relationship between maternal
 186 education and child BMI was -0.069 (-0.100, -0.037). The first scenario used SNP-based heritability
 187 estimates for years of education and BMI (see Table 1). In that scenario, the relationship between
 188 maternal education and child BMI further attenuated to -0.043 (-0.077,-0.009). In the twin heritability
 189 scenario, the estimate was null, meaning that, under this scenario, the entire association between
 190 maternal education and child BMI is accounted for by genetic confounding. Table 2 presents sensitivity
 191 analyses for BMI adjusting for both polygenic scores for the exposure and the outcome (GsensXY), only
 192 the outcome (GsensY), or only the exposure (GsensX). Estimates in bold are estimates from GsensXY
 193 reported in the text; other results presented in Table 2 are further explained in the next sections.

194 **Table 2. Sensitivity analysis for BMI**

			GsensXY	GsensY	GsensX
Best Fitting PS	Unconstrained	Residual ¹	-0.081 (-0.114;-0.048)	-0.069 (-0.101;-0.037)	-0.089 (-0.123;-0.055)
		G confound ²	-0.009 (-0.021;0.004)	-0.021 (-0.029;-0.013)	0.000 (-0.010;0.010)
	Constrained	Residual	-0.069 (-0.100;-0.037)	-0.069 (-0.100;-0.037)	-0.089 (-0.123;-0.055)
		G confound	-0.021 (-0.028;-0.013)	-0.021 (-0.028;-0.013)	0.000 (-0.010;0.010)
SNP heritability	Unconstrained	Residual	-0.060 (-0.097;-0.022)	-0.028 (-0.065;0.009)	-0.089 (-0.123;-0.056)
		G confound	-0.030 (-0.057;-0.002)	-0.061 (-0.086;-0.037)	0.000 (-0.009;0.009)
	Constrained	Residual	-0.043 (-0.077;-0.009)	-0.028 (-0.065;0.009)	-0.089 (-0.123;-0.055)
		G confound	-0.052 (-0.072;-0.033)	-0.061 (-0.086;-0.037)	0.000 (-0.010;0.009)
Twin heritability	Unconstrained	Residual	-	0.132 (0.036;0.230)	-0.089 (-0.127;-0.051)
		G confound	-	-0.222 (-0.320;-0.124)	-0.001 (-0.020;0.019)
	Constrained	Residual	0.00 (0;0)	0 (0;0)	-0.089 (-0.127;-0.051)
		G confound	-0.099 (-0.130;-0.067)	-0.098 (-0.130;-0.065)	-0.001 (-0.020;0.019)

195
 196 *Note.* Estimates and 95% CI are provided for each scenario. ¹Residual association after adjusting for
 197 genetic confounding. ²Genetic Confounding.

199 The observational estimate of the relationship between maternal education and child ADHD was-0.124
 200 (-0.152, -0.096). Using the best fitting polygenic scores for years of education and ADHD, the genetic
 201 confounding effect was estimated to be -0.018 (-0.027, -0.009), corresponding to 14.3% of the total

effect. After taking genetic confounding as captured by the polygenic scores into account, the relationship between maternal education and child ADHD attenuated to -0.106 (-0.135; -0.076). Table 3 shows results under different scenarios. In heritability-based scenarios, the relationship between maternal education and child ADHD was further attenuated, reducing to null in the twin-based scenario.

206

207 **Table 3. Sensitivity analysis for ADHD**

			GsensXY	GsensY	GsensX
Best Fitting PS	Unconstrained	Residual ¹	-0.106 (-0.135;-0.076)	-0.117 (-0.145;-0.089)	-0.107 (-0.137;-0.077)
		G confound ²	-0.018 (-0.027;-0.009)	-0.007 (-0.010;-0.004)	-0.017 (-0.026;-0.008)
	Constrained	Residual	-0.106 (-0.135;-0.076)	-0.117 (-0.145;-0.089)	-0.107 (-0.136;-0.077)
		G confound	-0.018 (-0.027;-0.009)	-0.007 (-0.010;-0.004)	-0.017 (-0.026;-0.008)
SNP heritability	Unconstrained	Residual	-0.063 (-0.158;0.031)	-0.01 (-0.074;0.054)	-0.108 (-0.138;-0.079)
		G confound	-0.061 (-0.153;0.032)	-0.114 (-0.173;-0.055)	-0.016 (-0.024;-0.008)
	Constrained	Residual	-0.052 (-0.096;-0.008)	-0.01 (-0.074;0.054)	-0.107 (-0.136;-0.077)
		G confound	-0.078 (-0.113;-0.043)	-0.114 (-0.173;-0.055)	-0.016 (-0.025;-0.008)
Twin heritability	Unconstrained	Residual	-	-	-0.089 (-0.123;-0.055)
		G confound	-	-	-0.035 (-0.053;-0.017)
	Constrained	Residual	0 (0;0)	0 (0;0)	-0.089 (-0.123;-0.055)
		G confound	-0.129 (-0.158;-0.1)	-0.127 (-0.156;-0.099)	-0.035 (-0.053;-0.017)

208

209 *Note.* Estimates and 95% CI are provided for each scenario. ¹Residual association after adjusting for
 210 genetic confounding. ²Genetic Confounding.

211

212 *Model constraints*

213 Tables 2 and 3 present constrained and unconstrained models. Unconstrained models, while closely
 214 fitting the data, can yield manifestly impossible values such as heritabilities above 100%, standardized
 215 paths above 1, or negative variances, in which case estimates are unreliable (which was the case for
 216 empty cells in Table 2 and 3). Implausible values are also observed. For example, in Table 2, the
 217 unconstrained GsensY estimate in the twin heritability scenario is positive, which would correspond to
 218 higher maternal education being linked to higher rather than lower BMI in children. This is
 219 understandable given that the best fitting polygenic score, which explains only 6.3% of variance in child
 220 BMI already explains 23% of the negative association between maternal education and child BMI.
 221 Under the twin heritability scenario, with BMI heritability of 64%, the association is likely to flip to a

positive sign. This may be due to sampling. For example, if the cross path from BMI polygenic score to maternal education is, by chance, overestimated in TEDS, this will overestimate genetic confounding as captured by the polygenic score and impact estimation under the twin heritability scenario. It may also be because the true heritability of BMI is overestimated by the twin design. The constrained models therefore impose constraints on parameters to avoid impossible values (standardized paths above one and negative variances) and implausible values (cross-paths and residual associations flipping sign). While these models fit the observed data less well than the unconstrained models, they accommodate our prior beliefs about the plausible range of parameter values.

Bias amplification and simulations

Gsens uses estimates of heritability that provide useful benchmarks to estimate the extent of genetic confounding. It provides estimates of the strength of genetic confounding and of the residual association comprising the causal effect plus association through non-genetic confounders. However, these estimates are biased by the association between genetic and non-genetic confounders induced by conditioning on the exposure X , an instance of collider bias (see Methods). The bias is most pronounced when adjusting for polygenic scores that explain more variation in X than in Y , and may lead to estimates of residual association that are more biased than the observational association, a phenomenon termed bias amplification [21]. We therefore expect more bias amplification for $Gsens_X$ compared to $Gsens_Y$.

We conducted two sets of simulations based on the underlying causal model presented in Methods. In the first, we simulated polygenic scores capturing all genetic influences to examine the effect of bias amplification independent of measurement error. We compared estimates from the three *Gsens* functions to the true residual association net of genetic confounding (comprising the causal effect and non-genetic confounding). As shown in Figure 2, bias amplification can be particularly severe when there is no genetic confounding (top left panel, Figure 2), and when the heritability of X is high (bottom left panel,

12

Genetic confounding 12

247 Figure 2). In such cases, adjusted estimates can indeed be higher than the observational association. In
248 the presence of genetic confounding, the adjusted estimates are always closer to the true residual
249 association than to the observational association (top and bottom right panels, Figure 2). However, bias
250 is still present. Bias is greatest for G_{sensXY} and G_{sensX} . However, in all cases, estimates from G_{sensY}
251 have little or no bias, even when the heritability of X and the genetic correlation are high (bottom right
252 panel, Figure 2). When there is no non-genetic confounding (0 on the X-axis), bias amplification does
253 not occur and all G_{sens} estimators recover the causal effect.

254
255
256
257
258
259

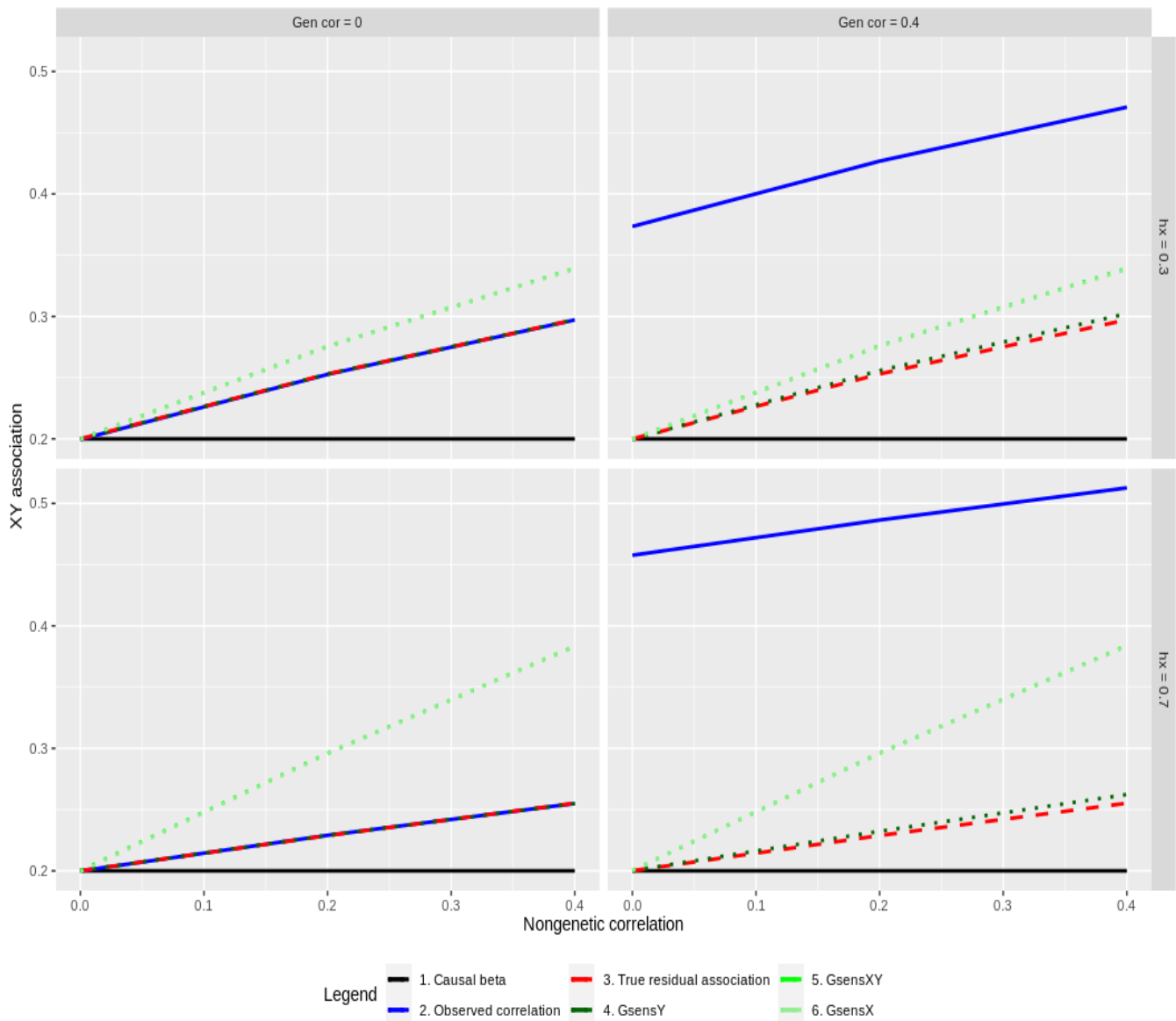

261

262 **Figure2. Bias amplification: simulation results**

263 The standardized association between X and Y (Y-axis) is plotted as a function of the correlation between the
 264 non-genetic factors for X and Y that generate non-genetic confounding (X-axis). The figure is faceted left to right
 265 according to the genetic correlation that generates genetic confounding (gen cor), and top to bottom according to
 266 the heritability of X (h_x). A subset of results is plotted with causal effect = 0.20, $N = 10,000$, heritability of Y =
 267 70% and the full set of results is provided in S2. Note that estimates from GsensX and GsensXY are very similar
 268 in this first set of simulations but can differ in the second when polygenic scores are set to capture varying levels
 269 of the heritability of X and Y.

270

271 In the second set, we simulated polygenic scores that captured only a fraction of heritability. We

272 simulated scenarios under which the polygenic score for X captures more of the variance of Y than the

273 polygenic score for Y itself. This may happen with differentially powered GWAS. In our empirical

274 example, the polygenic score for education captures almost as much variance in ADHD than the
275 polygenic score for ADHD itself. Conceivably under such scenarios, using *GsensX* or *GsensXY* may
276 better account for genetic confounding than *GsensY*. In our example, both *GsensX* and *GsensXY* using
277 the polygenic score for education found a larger genetic confounding effect than when using the
278 polygenic score for ADHD in *GsensY* alone. However, our simulations showed that, even under such
279 circumstances, bias amplification under twin heritability scenarios remains larger for *GsensX* and
280 *GsensXY*. Results are reported in S2.

281 In the two sets of simulations, constraints imposed on the model to avoid impossible or implausible
282 results often removed part or all bias. However, we caution against systematically applying constraints
283 as they do not necessarily remove bias and may artificially reduce standard errors. Results of
284 constrained models, as well as standard errors for all models, are reported in S2. Of note, standard
285 errors for *GsensY* were systematically lower than for *GsensX* and *GsensXY*. Empirical standard errors
286 closely matched the analytic estimates.

287 These results suggest that *GsensY* should be preferred in all situations and that *Gsens* is best adapted
288 when the outcome of interest is strongly predicted by its polygenic score. When the polygenic score for
289 the exposure is more predictive, *GsensXY* can be used, particularly to estimate genetic confounding
290 with observed polygenic scores, but should be interpreted with caution under heritability scenarios.

291 Importantly, simulations show that small remaining bias for *GsensY* is conservative in the sense that it
292 underestimates genetic confounding. This lessens the risk of overadjusting the association between *X*
293 and *Y*.

295

296

297

298

299

Discussion

In the present study, we combined polygenic scores with heritability estimates in a genetic sensitivity analysis – *Gsens* – aiming to gauge to what extent genetic confounding can account for observed epidemiological associations. The genetic sensitivity analysis we propose adds a new tool to probe the robustness of associations between exposures and outcomes. This approach requires a genotyped cohort with relevant phenotypic measurements, which is increasingly the rule for epidemiological cohorts rather than the exception. It is therefore possible to envisage *Gsens* analysis becoming routine. Below, we first discuss our empirical findings regarding the associations between maternal education and child educational attainment, BMI, and ADHD. We then discuss the interpretation and applicability of *Gsens*.

Maternal education and developmental outcomes

Our findings show that the association between maternal education and developmental child outcomes were still present under a SNP-heritability scenario but were null under a twin-heritability scenario. Overall, the observed association between maternal education and these three developmental outcomes may largely be due to genetic confounding.

Relevant to our findings is previous research using causal inference designs to investigate the effect of parental educational attainment on child educational attainment. In particular, a systematic review on the topic has summarized evidence from twin and adoption designs, as well as non-genetic instrumental variable estimations [22]. The systematic review suggested that intergenerational associations between parent and child educational attainment are largely driven by selection effects, including genetic confounding; it suggests only small but still significant causal effects. A new method – the ‘virtual-parent design’ – has recently emerged, which consists of splitting parental genetic variants associated with a parental exposure into variants transmitted and nontransmitted to the child [20,23]. Parental polygenic scores including only nontransmitted variants are free from genetic confounding and index

325 plausible causal effects of the parental exposure on the child outcome. Empirical findings implementing
326 this method in education research suggest substantial genetic confounding and small but still significant
327 causal effects of parental attainment on child attainment. Our findings on educational attainment are
328 consistent overall with this literature. Although genetic confounding accounted entirely for the
329 association between parental education attainment and child achievement, we detected a small but
330 significant effect when using the upper theoretical limit of the k parameter, consistent with previous
331 findings. In addition, scenarios based on lower heritability estimates also yielded small but significant
332 effects, raising the possibility that null findings resulted from overestimated twin heritability estimates, a
333 possibility further discussed below. Taken together, this set of findings represents a clear call for caution
334 when interpreting non-genetically informed epidemiological studies on the role of maternal education.

336 *Interpreting the sensitivity to genetic confounding analysis*

337 Two key points regarding the interpretation of *Gsens* findings must be highlighted. First, the reliability
338 of findings depends on the accuracy of heritability estimates. Overestimating heritability would lead to
339 overestimating genetic confounding and thus underestimating the residual association between exposure
340 and outcome. For example, a recent study of 193,518 twins across 16 countries has showed that
341 educational attainment is 43% heritable [24]. As can be seen in Figure 1, this lower estimate would lead
342 to a substantially larger adjusted association. Improved estimates of heritability that better reflect true
343 genetic effects can be plugged into our method as they become available. In addition, power increase in
344 GWAS will improve the reliability of *Gsens* in the following ways: (i) by increasing the predictive
345 power of polygenic scores and therefore the accuracy of observed scenarios; (ii) by improving the
346 accuracy of parameter estimates for the sensitivity analysis.

347 Second, *Gsens* aims to estimate genetic confounding and the residual association net of genetic
348 confounding. This is distinct from the genetic overlap as estimated by bivariate twin or mixed-model
349 methods, which decomposes the phenotypic association into genetic and environmental components

350 (the percentage of the phenotypic correlation that is due to genetic overlap is called bivariate
351 heritability). This is because a genetic correlation can arise from genetic effects on the outcome
352 mediated via the exposure and the causal path (i.e. mediated pleiotropy) or by direct genetic effects on
353 the outcome (i.e. unmediated pleiotropy). In twin-based methods, the corresponding residual association
354 is an environmental association in that it excludes all genetic components from the observed association,
355 including those mediated by the causal effect. In contrast, *Gsens* aims to remove only the genetic
356 confounding or unmediated pleiotropy. In the absence of nongenetic confounding, the *Gsens* residual
357 association would correspond to the causal effect, while the environmental association would be lower
358 than the causal effect. Further clarifications regarding these conceptual differences can be found in S1
359 Annex 1.

360 In contrast, a conceptually similar approach to ours is taken in the latent causal variable (LCV) model
361 [25], which also estimates genetic confounding parameters without identifying the causal effect of the
362 exposure. The emphasis of LCV is however on comparing the genetic confounder effects on the risk
363 factor to those on the outcome. Mendelian Randomization (MR) methods impose stronger assumptions
364 on the genetic confounding effects to explicitly identify the causal effects [26]. In comparison with MR
365 and LCV methods, our approach requires only the standard assumptions of structural equation
366 modelling, and retains much of the precision of the observational association. However we cannot
367 identify the causal effect from the residual association, unless we assume no non-genetic confounding.
368 We contend that where there is substantial genetic confounding, our approach provides insights into the
369 likely existence and magnitude of a causal effect. Indeed, our approach recreates a standard regression
370 adjustment for a polygenic score explaining the entire heritability, should such a score be available. In
371 this respect we follow traditional lines of sensitivity analysis in epidemiological studies, accepting that
372 bias may still remain from residual confounding.

373

374 ***Limitations and research avenues***

375 As TEDS does not include parental genotypes, we did not model their role directly. Where such data are
376 available, *Gsens* could be extended in the intergenerational context. However, although our examples
377 were of intergenerational associations, *Gsens* can be generally implemented when both the exposure and
378 the outcome are measured for the same individuals, without considering parental effects. Furthermore,
379 providing the sampling populations are exchangeable, it is not necessary for the genetic and
380 observational associations, nor the heritabilities, to be estimated in the same data sets. *Gsens* may be
381 extended in future to explicitly consider measured confounders, which may further reduce residual
382 amplification bias due to nongenetic confounding.

383 ***Conclusions***

384 We propose a genetic sensitivity analysis aiming to adjust for genetic confounding in epidemiological
385 associations. *Gsens* implements structural equation models to adjust for genetic confounding based on
386 polygenic scores and heritability estimates. *Gsens* can be applied as long as a suitable GWAS for the
387 outcome is available, even when a GWAS for the exposure is not available or does not provide adequate
388 instruments for MR analyses. For example, *Gsens* can be applied to test whether the association between
389 urbanicity and schizophrenia is susceptible to genetic confounding based on the polygenic score and
390 heritability estimates for schizophrenia. We therefore propose that *Gsens* can be conceived as a
391 complementary method, suited for complex environmental exposures that are of interest for health,
392 behavioural and social sciences.

393

394

395

Methods

396

Participants

397 Participants were drawn from the Twins Early Development Study (TEDS), a longitudinal study
398 of twin pairs born in England and Wales, between 1994 and 1996. Detail regarding TEDS, the
399 recruitment process, and representativeness can be found elsewhere [27]. A total of 7,026 unrelated

400 individuals have been genotyped in TEDS. For each individual analysis, sample size comprised between
401 3,663 to 4,693 individuals with data for maternal education and each outcome. Written consent was
402 obtained from all the families who agreed to take part in the study. This study was approved by the
403 Institute of Psychiatry, Kings College London, Ethics Committee.

404

405 **Measures**

406 Maternal educational attainment was reported by mothers at first contact, when children were on
407 average 18 months old, with 8 levels: 1= no qualifications; 2 = CSE grade 2-5 or O-level/GCSE grade
408 D-G; 3 = CSE grade 1 or O-level/GCSE grade A-C; 4 = A-level or S-level; 5 = HNC; 6 = HND; 7=
409 undergraduate degree; 8 = postgraduate qualification.

410

411 *Child educational achievement* was operationalized as performance on the standardized UK-wide
412 examination, the General Certificate of Secondary Education (GCSE), at 16 years. We computed a mean
413 of the three compulsory core subjects, mathematics, English, and science (further details in [10]). A total
414 of 3,785 genotyped individuals had data on both maternal education and child GCSE.

415 Body Mass Index (BMI) was derived from parent reported (ages 11 and 14 years) and self-reported
416 weight and height (age 16 years). Extreme BMI values (<1% and >99% quantiles) were winsorized and
417 resulting values were averaged across ages 11 to 16 years. A total of 3,663 genotyped individuals had
418 data on maternal education and the resulting BMI score.

419 The DSM-IV ADHD symptom subscale, taken from the Conners' Parent Rating Scales–Revised [28]
420 was completed by mothers to assess inattentive and hyperactive/impulsive symptoms (9 for
421 hyperactivity/impulsivity and 9 for inattention). Each item was rated on a 4-point Likert scale ranging
422 from 0 (not at all true) to 3 (very much true). A total ADHD score was created by averaging scores
423 across the following mean ages of participants at assessments: 8, 11, 14, and 16 years. The score
424 measures population symptoms dimensionally and not the clinical disorder. A total of 4,693 genotyped

425 individuals had data on maternal education and the ADHD score.

426

427 ***Analyses***

428 Genotyping, quality control procedures and principal component analysis are detailed in S1 section 1. A

429 total sample of 7,026 participants with European ancestry remained after quality control. Single

430 Nucleotide Polymorphisms (SNPs) were excluded if the minor allele frequency was <5%, if more than

431 1% of genotype data were missing, or if the Hardy Weinberg p-value was lower than 10^{-5} . Non-

432 autosomal markers and indels were removed.

433 We computed genome-wide polygenic scores based on summary statistics from the following genome-

434 wide association studies (GWAS): (i) years of education [29]; (ii) ADHD [13]; and (iii) BMI [11]. In

435 some cases, like ADHD, the GWAS phenotypes do not match our measures exactly; however they still

436 explain substantial variation and can be extrapolated up to the heritability of our measure. Polygenic

437 scores for all TEDS participants and all traits were computed using PRSice software [15], with prior

438 clumping to remove SNPs in linkage disequilibrium ($r^2 > 0.10$). PRSice allowed us to select the best-

439 fitting polygenic score for each trait, e.g. maximizing the amount of variance explained by the polygenic

440 score for BMI in TEDS participants' BMI. To this end, we computed a series of polygenic scores

441 including an increasing number of SNPs corresponding to increasing p-value thresholds (e.g. all SNPs

442 associated to BMI at $p < .0001$ and $p < .10$) as illustrated in S1 eFigures 1, 2, & 3. Using linear regression

443 analyses, we estimated the proportion of variance explained by each generated polygenic score in the

444 corresponding trait in TEDS. The following covariates were included in regression analyses: sex, age

445 (for GCSE), and 10 principal components of ancestry.

446

447 ***Genetic confounding***

448 We assume a linear structural equation model framework [30]. Akin to third variable confounding,

449 genetic confounding is represented in Figure 3a: genetic factors (G) – here measured by polygenic

score(s) – influence both the exposure (X) and the outcome (Y). MacKinnon et al. demonstrated that mediation and confounding are statistically identical in linear structural equation modelling [31]. Therefore, genetic confounding can be estimated by treating the confounder– here the polygenic score G – as a mediator of the effect of X and Y (Figure 3b). The confounding effect is the indirect effect of X on Y through G: $\beta_{XG}\beta_{GY}$. We also calculated the proportion of the observed effect of X on Y that is

accounted for by genetic confounding, i.e. $\frac{\hat{\beta}_{XG}\hat{\beta}_{GY}}{\beta_{XG}\beta_{GY} + \beta_{XY}}$.

Figure 3. Genetic confounding, one polygenic score case.

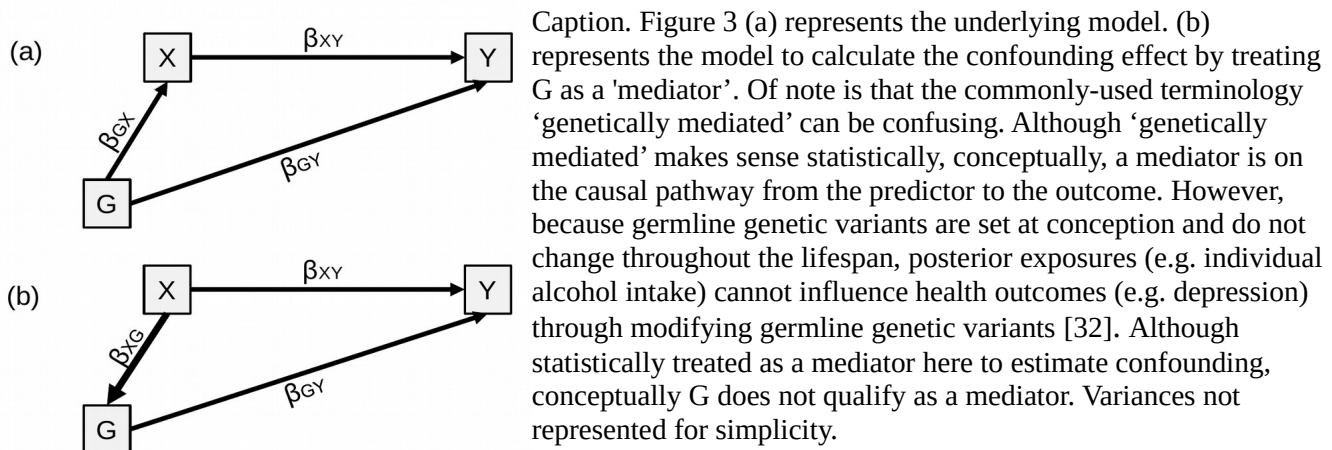

When the polygenic scores for the predictor (G1) is different from the polygenic score for the outcome

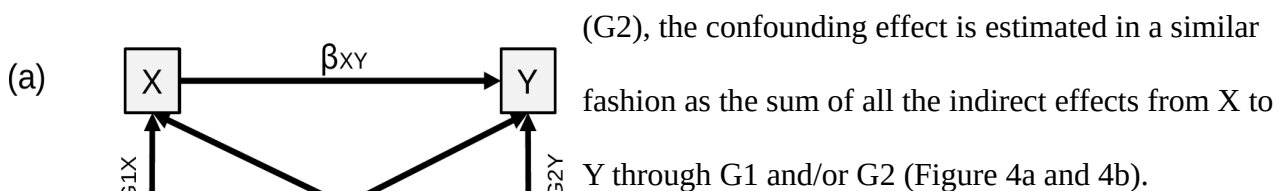

Figure 4. Genetic confounding, two polygenic score.

Caption. Figure 4a represents the underlying causal model. Figure 4b represents the model to calculate the confounding effect, which is equal to: $\beta_{XG_1}\beta_{G_1Y} + \beta_{XG_2}\beta_{G_2Y}$. Note that when model variables are standardized, the genetic confounding effect can also be obtained based on 4a

485 by $\beta_{G_1X}\beta_{G_1Y} + \beta_{G_2X}\beta_{G_2Y} + \beta_{G_1X}\beta_{G_1G_2}\beta_{G_2Y} + \beta_{G_2X}\beta_{G_1G_2}\beta_{G_1Y}$ Variances not represented for simplicity.

486

487

488

489

490

491 Genetic confounding effects were calculated for all three developmental outcomes:

- 492 • Maternal education to child educational achievement using the best-fitting polygenic score for
493 years of education (as in Figure 3);
- 494 • Maternal education to child BMI using best-fitting polygenic scores for years of education (G1)
495 and BMI (G2) (as in Figure 4);
- 496 • Maternal education to child ADHD symptoms using best-fitting polygenic scores for years of
497 education (G1) and ADHD symptoms (G2) (as in Figure 4).

498

499 In these analyses, the effect size of X on Y decreases as a function of the strength of genetic
500 confounding. However, this approach does not account for all the genetic confounding. This is because
501 polygenic scores based on current GWAS capture a relatively small amount of all genetic influences. For
502 example, the current polygenic score for BMI explains around 6% of the variance in BMI in TEDS, far
503 less than SNP-based and twin heritability estimates of BMI heritability. The sensitivity analysis we
504 propose aims to address this issue.

505

506 ***Sensitivity analysis***

507 The sensitivity analysis aims to answer the following question: is X is associated with Y after we control
508 for all genetic confounding? In other words, to what extent would β_{XY} decrease if we were to control for
509 ‘perfect’ polygenic scores capturing all genetic influences on X and Y rather than a small fraction. This
510 is done by estimating β_{XY} under plausible scenarios that combine information on existing polygenic

511 scores and heritability estimates.

512

513 **Single polygenic score.** For maternal education and child educational achievement, we used a polygenic
514 score for the child, derived from the GWAS of years of education, which predicts a substantial amount
515 of variance both in child GCSE but also in maternal education. The effect of maternal education on child
516 educational attainment can be first adjusted for the observed best-fitting polygenic score. However, this
517 polygenic score does not capture all the heritability of the outcome and therefore incompletely adjusts
518 for genetic confounding. The sensitivity analysis consists in re-examining the effect of maternal
519 education under scenarios where the polygenic score could capture additional variance in child GCSE
520 up to SNP-based and twin-based estimates of heritability.

521 Figure 3a shows the underlying model of relationships between the polygenic score (G), the predictor
522 (X) and the outcome (Y). We can obtain an adjusted effect of X on Y based on the observed associations
523 available with the following expression:

$$524 \beta_{XY} = (r_{XY} - r_{GX} r_{GY}) / (1 - r_{GX}^2) \quad (1)$$

525 where β_{XY} is the adjusted effect and r denotes observed standardized associations. Details are presented
526 in S1 section 2. Importantly, β_{XY} corresponds to the standardized association between X and Y minus
527 genetic confounding, i.e. the residual association between X and Y net of genetic confounding. In other
528 words, G_{sens} removes only genetic confounding and not all genetic effects shared between X and Y,
529 which comprise both genetic confounding and genetic effects on Y mediated by X via a causal pathway.
530 When subtracting all shared genetic effects, including those arising from the causal effect, the residual
531 association becomes the 'environmental association'. This is similar to what happens in bivariate
532 decomposition of the phenotypic correlation in twin and mixed model designs and is distinct from
533 G_{sens} estimates. This distinction is further clarified in S1 Annex 1.

534

535

24

Genetic confounding 24

536

537

538

539

540

541 **Figure 5. Sensitivity analysis, one polygenic score.**

542

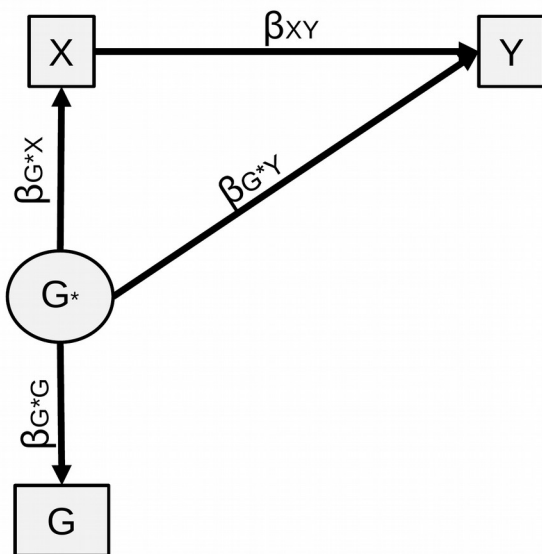

543

544

545

546

547

548

549

550

551

552

553

554

555

556

557

558

559

When using the best-fitting polygenic score, β_{XY} can be estimated using standardized associations between the observed polygenic score, X and Y, as in expression (1). In the sensitivity analysis, a structural equation model is fitted with a latent variable G^* representing heritability, as presented in Figure 5. This can be understood as correcting for measurement error, i.e. G being an imperfect measure of G^* . Genetic confounding estimated under this model reflects heritability under the chosen scenario rather than only what is captured by the polygenic score. We fitted structural equation models using the R package ‘lavaan’ [33]. The latent variable is set to capture the heritability of Y under the sensitivity analysis scenario (e.g. twin-heritability). The following constraint is applied:

$\beta_{G^*Y} + \beta_{G^*X}\beta_{XY} = \sqrt{h_y^2}$. Variances not represented for simplicity.

560 **Complete genetic confounding.** In equation (1), the association between X and Y is completely

561 genetically confounded when the adjusted effect $\beta_{XY} = 0$. We can then express the observed standardized

562 association as a function of the heritabilities of X and Y under complete genetic confounding as:

563
$$r_{XY} = r_{GX} r_{GY} = \sqrt{h_x^2} \sqrt{h_y^2} \quad (2)$$

564 When the adjusted effect of X on Y is null, then r_{XY} is equal to genetic effects through G. In the special

565 case where X and Y are the same trait in parent and child and assuming constant heritability across

566 generations, we thus obtain:

567
$$r_{XY} = 0.5 * \sqrt{h_y^2} \sqrt{h_y^2} = 0.5 h_y^2 \quad (3)$$

568 This means that the adjusted effect of X on Y is likely to be null whenever the observed association does
569 not exceed half of the trait heritability. As such, a given association between parental and child traits can
570 be assessed against Figure 6 and if it lies in the shaded area, it is consistent with complete genetic
571 confounding. Importantly, associations not in the shaded area can still be confounded by environmental
572 exposures. See S1 section 3 for additional details on equations (2) and (3).

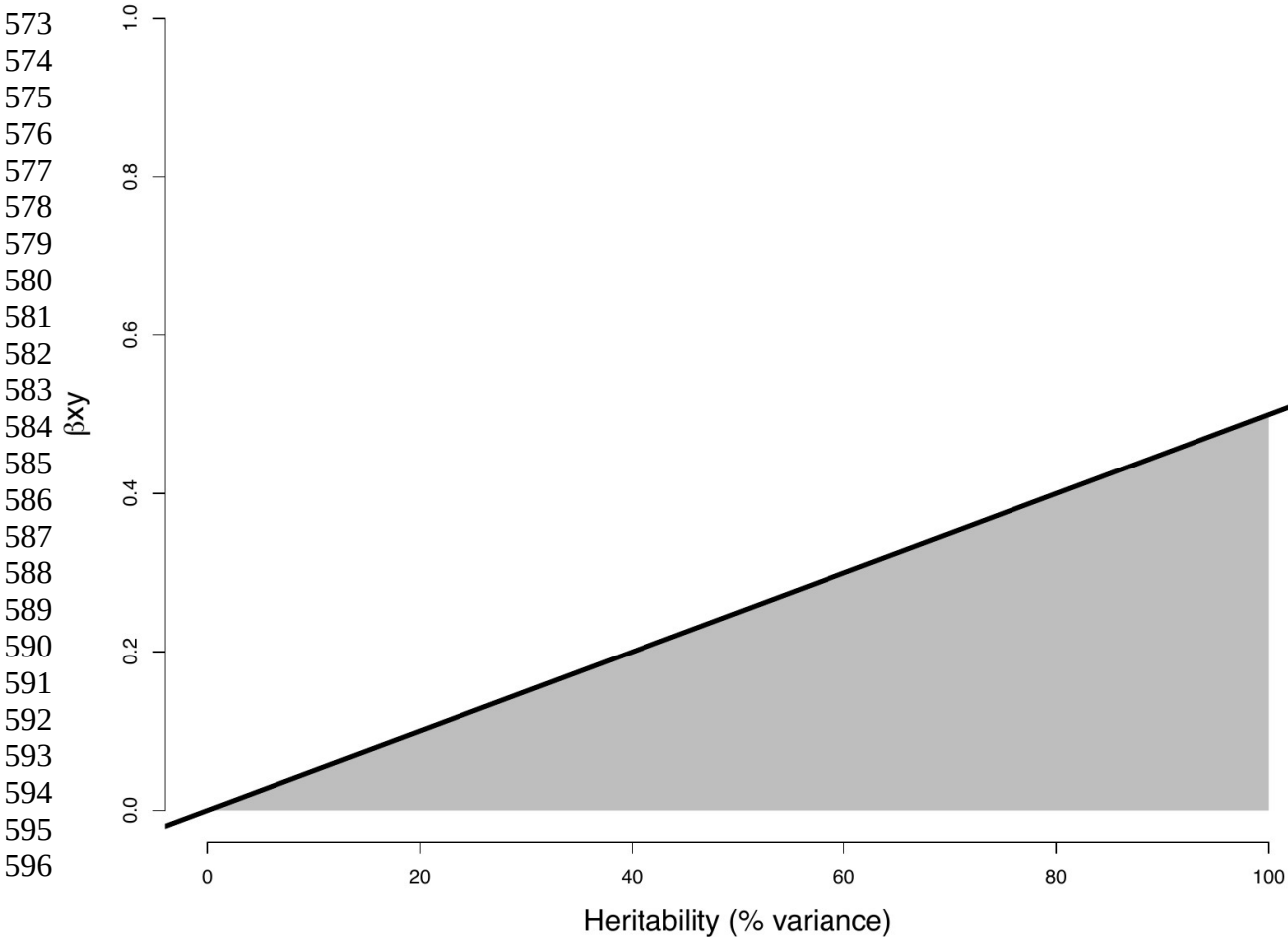

597 **Figure 6. The role of genetics in explaining phenotypic associations between parent and child**
598 *Caption.* Standardized observed associations between the same traits in the mother (or father) and the child are
599 represented as a function of trait heritability. An observed association of 0.20 with trait heritability of 0.60 is consistent
600 with complete genetic confounding. Conversely, an association of 0.40 with heritability of 0.40 is not consistent with
601 complete genetic confounding .
602

603 **The two polygenic scores case**

604 When predictor and outcome are different variables – for example maternal education and child BMI –
605 two polygenic scores can be used in the sensitivity analysis, as shown in Figure 4. In theory, if we had a
606 polygenic score capturing all genetic influences for Y, this score would also capture all the genetic
607 overlap between X and Y, and we could use the one polygenic score case above. In practice, polygenic

608 scores do not capture all genetic influences on their respective phenotypes and are differentially
 609 powered, which is why we examine the utility of a two polygenic scores solution. In the two polygenic
 610 scores case, new parameters are introduced including the cross paths from each polygenic score to the
 611 other phenotype (β_{G_1Y} and β_{G_2X}). Due to these new parameters, the derivation of β_{XY} becomes more
 612 complex than for the single case polygenic score. We thus generalize the structural equation model to
 613 two latent variables and polygenic scores as in Figure 7. Further details in S1 Section 4.

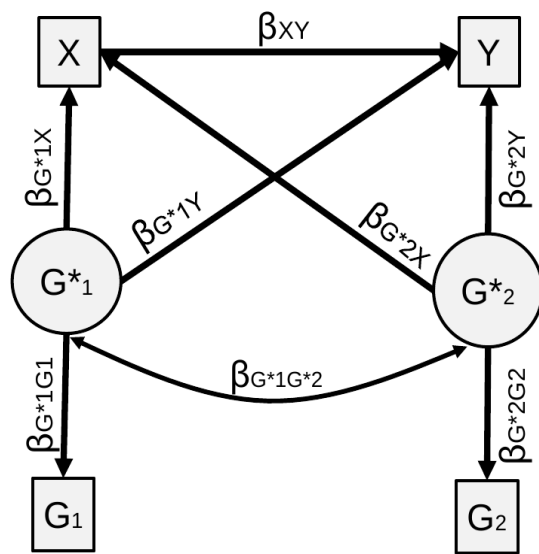

Figure 7: Sensitivity analysis, two polygenic scores.

The following constraints are imposed on the model:

$$\beta_{G^*1X} + \beta_{G^*1G^*2} \beta_{G^*2X} = \sqrt{(h_x^2)} \text{ and}$$

$$\beta_{G^*2Y} + (\beta_{G^*2X} + \beta_{G^*1G^*2} \beta_{G^*1X}) \beta_{XY} + \beta_{G^*1G^*2} \beta_{G^*1Y} = \sqrt{(h_y^2)}$$

Variances not represented for simplicity.

624

625 Model assumptions

626

627 Our approach requires the standard assumptions of structural equation modelling, including normality of
 628 the observed and latent variables and no unmodelled confounding or interaction effects. For polygenic
 629 traits the normality assumptions are reasonable. Note that although polygenic scores are constructed
 630 from additive models, we make no such assumption for the true latent genetic value, only that it has a
 631 linear relationship with the polygenic score. Unmodelled confounders can create bias amplification, as
 632 we show in our simulations. However note that all heritable confounders would be included in the latent
 633 genetic values under the heritability scenarios, and so only the non-genetic components of unmodelled
 634 confounders would create bias.

635

636 **Simulations**

637 In order to verify the performance of *Gsens* under its own assumptions, and to study the possibility of
 638 bias amplification, we conducted simulations based on the underlying causal model presented in Figure
 639 8. Simulations were conducted with the `SimulateData()` function in package 'lavaan' embedded within
 640 the wrapper simulation package `SimDesign` [34,35].

641 In the first set of simulations, loadings from G_1^* to G_1 and G_2^* to G_2 were fixed to unity (thereby
 642 simulating polygenic scores capturing the whole heritability) in order to examine amplification bias
 643 independently of the latent structure of the model. We chose parameters based on reasonable values,
 644 with the following combinations: X and Y were 30% or 70% heritable, and influenced by respective
 645 non-genetic influences of 55% or 15% (leaving 15% of unexplained variance); genetic and non-genetic
 646 correlations of 0 or 0.40; a causal effect of 0 or 0.2.

647 In the second set of simulations, we fixed the causal effect to 0.20 and heritabilities to 70% but values of
 648 the loadings were set so that the resulting polygenic scores G_1 and G_2 would capture 1% or 10% of the
 649 variance of X and Y, respectively. This resulted in either polygenic scores with equal explanatory power
 650 or asymmetric situations where, e.g. one polygenic score explained 10% of the variance in X and the
 651 other polygenic score explained only 1% of the variance in Y.

652 In this case, the resulting association between the first
 653 polygenic score and Y may actually be greater than the
 654 association between the second and Y, which can result in
 655 non-null cross-paths. Such a situation can stem from the
 656 differential accuracy of GWAS for X and Y.

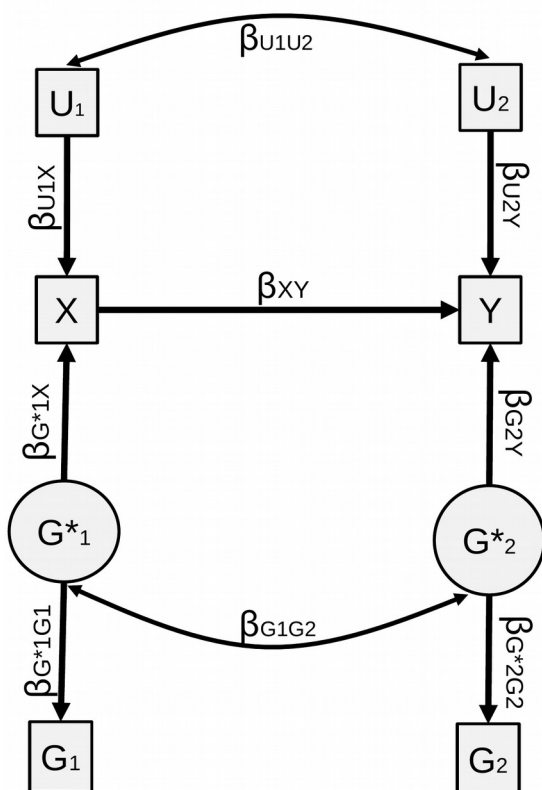

657 **Figure 8. Simulation generative model**
 658 The figure represents the generative model for simulations.
 659

661

662

663

664

665

666

667

668

669

Acknowledgments

670 We gratefully acknowledge the ongoing contribution of the participants in the Twins Early Development
671 Study (TEDS) and their families. This project has received funding from the European Research
672 Council (ERC) under the European Union's Horizon 2020 research and innovation programme (grant
673 agreement No. 863981) and the MRC (MR/S037055/1). We are grateful to Dr. Jessie Baldwin for
674 comments on the manuscript and the tutorial.

675

676

677

References

1. Fisher RA. Alleged dangers of cigarette-smoking. *Br Med J*. 1957;2: 4 & 297–298.
2. Greenhouse JB. Commentary: Cornfield, Epidemiology and Causality. *Int J Epidemiol*. 2009;38: 1199–1201. doi:10.1093/ije/dyp299
3. Cornfield J, Haenszel W, Hammond EC, Lilienfeld AM, Shimkin MB, Wynder EL. Smoking and lung cancer: recent evidence and a discussion of some questions. 1959. *Int J Epidemiol*. 2009;38: 1175–1191. doi:10.1093/ije/dyp289
4. Pingault J-B, O'Reilly PF, Schoeler T, Ploubidis GB, Rijdsdijk F, Dudbridge F. Using genetic data to strengthen causal inference in observational research. *Nat Rev Genet*. 2018;19: 566–580. doi:10.1038/s41576-018-0020-3
5. Pingault J-B, Viding E, Galéra C, Greven CU, Zheng Y, Plomin R, et al. Genetic and environmental influences on the developmental course of attention-deficit/hyperactivity disorder symptoms from childhood to adolescence. *JAMA Psychiatry*. 2015;72: 651–658. doi:10.1001/jamapsychiatry.2015.0469

6. Magnuson K. Maternal education and children's academic achievement during middle childhood. *Dev Psychol.* 2007;43: 1497–1512. doi:10.1037/0012-1649.43.6.1497
7. Rydell A-M. Family factors and children's disruptive behaviour: an investigation of links between demographic characteristics, negative life events and symptoms of ODD and ADHD. *Soc Psychiatry Psychiatr Epidemiol.* 2010;45: 233–244. doi:10.1007/s00127-009-0060-2
8. Parizkova J. Impact of education on food behaviour, body composition and physical fitness in children. *Br J Nutr.* 2008;99 Suppl 1: S26-32. doi:10.1017/S0007114508892483
9. Krapohl E, Rimfeld K, Shakeshaft NG, Trzaskowski M, McMillan A, Pingault J-B, et al. The high heritability of educational achievement reflects many genetically influenced traits, not just intelligence. *Proc Natl Acad Sci U S A.* 2014;111: 15273–15278. doi:10.1073/pnas.1408777111
10. Krapohl E, Plomin R. Genetic link between family socioeconomic status and children's educational achievement estimated from genome-wide SNPs. *Mol Psychiatry.* 2015 [cited 14 Nov 2015]. doi:10.1038/mp.2015.2
11. Locke AE, Kahali B, Berndt SI, Justice AE, Pers TH, Day FR, et al. Genetic studies of body mass index yield new insights for obesity biology. *Nature.* 2015;518: 197–206. doi:10.1038/nature14177
12. Okbay A, Beauchamp JP, Fontana MA, Lee JJ, Pers TH, Rietveld CA, et al. Genome-wide association study identifies 74 loci associated with educational attainment. *Nature.* 2016;533: 539–542. doi:10.1038/nature17671
13. Demontis D, Walters RK, Martin J, Mattheisen M, Als TD, Agerbo E, et al. Discovery of the first genome-wide significant risk loci for ADHD. *bioRxiv.* 2017; 145581. doi:10.1101/145581
14. Lambert SA, Gil L, Jupp S, Ritchie SC, Xu Y, Buniello A, et al. The Polygenic Score Catalog: an open database for reproducibility and systematic evaluation. *medRxiv.* 2020; 2020.05.20.20108217. doi:10.1101/2020.05.20.20108217
15. Euesden J, Lewis CM, O'Reilly PF. PRSice: Polygenic Risk Score software. *Bioinforma Oxf Engl.* 2015;31: 1466–1468. doi:10.1093/bioinformatics/btu848
16. Bulik-Sullivan BK, Loh P-R, Finucane HK, Ripke S, Yang J, Schizophrenia Working Group of the Psychiatric Genomics Consortium, et al. LD Score regression distinguishes confounding from polygenicity in genome-wide association studies. *Nat Genet.* 2015;47: 291–295. doi:10.1038/ng.3211
17. Bulik-Sullivan B, Finucane HK, Anttila V, Gusev A, Day FR, Loh P-R, et al. An atlas of genetic correlations across human diseases and traits. *Nat Genet.* 2015;47: 1236–1241. doi:10.1038/ng.3406
18. Zheng J, Erzurumluoglu AM, Elsworth BL, Kemp JP, Howe L, Haycock PC, et al. LD Hub: a centralized database and web interface to perform LD score regression that maximizes the potential of summary level GWAS data for SNP heritability and genetic correlation analysis. *Bioinformatics.* 2017;33: 272–279. doi:10.1093/bioinformatics/btw613
19. Wood AC, Buitelaar J, Rijdsdijk F, Asherson P, Kuntsi J. Rethinking Shared Environment as a Source of Variance Underlying Attention-Deficit/Hyperactivity Disorder Symptoms: Comment on. *Psychol Bull.* 2010;136: 331–340. doi:10.1037/a0019048

20. Bates TC, Maher BS, Medland SE, McAloney K, Wright MJ, Hansell NK, et al. The nature of nurture: Using a virtual-parent design to test parenting effects on children's educational attainment in genotyped families. *Twin Res Hum Genet.* 2018;21: 73–83. doi:10.1017/thg.2018.11
21. Myers JA, Rassen JA, Gagne JJ, Huybrechts KF, Schneeweiss S, Rothman KJ, et al. Effects of Adjusting for Instrumental Variables on Bias and Precision of Effect Estimates. *Am J Epidemiol.* 2011;174: 1213–1222. doi:10.1093/aje/kwr364
22. Holmlund H, Lindahl M, Plug E. The causal effect of parents' schooling on children's schooling: A comparison of estimation methods. *J Econ Lit.* 2011;49: 615–651.
23. Kong A, Thorleifsson G, Frigge ML, Vilhjalmsdottir BJ, Young AI, Thorgeirsson TE, et al. The nature of nurture: Effects of parental genotypes. *Science.* 2018;359: 424–428. doi:10.1126/science.aan6877
24. Silventoinen K, Jelenkovic A, Sund R, Latvala A, Honda C, Inui F, et al. Genetic and environmental variation in educational attainment: an individual-based analysis of 28 twin cohorts. *Sci Rep.* 2020;10: 12681. doi:10.1038/s41598-020-69526-6
25. O'Connor LJ, Price AL. Distinguishing genetic correlation from causation across 52 diseases and complex traits. *Nat Genet.* 2018;50: 1728–1734. doi:10.1038/s41588-018-0255-0
26. Dudbridge F. Polygenic Mendelian Randomization. *Cold Spring Harb Perspect Med.* 2020; a039586. doi:10.1101/cshperspect.a039586
27. Haworth CMA, Davis OSP, Plomin R. Twins Early Development Study (TEDS): a genetically sensitive investigation of cognitive and behavioral development from childhood to young adulthood. *Twin Res Hum Genet.* 2013;16: 117–125. doi:10.1017/thg.2012.91
28. Conners CK. *Conners' Rating Scales-Revised: Technical Manual.* New York: Multi-Health System Inc.; 2003.
29. Lee JJ, Wedow R, Okbay A, Kong E, Maghazian O, Zacher M, et al. Gene discovery and polygenic prediction from a genome-wide association study of educational attainment in 1.1 million individuals. *Nat Genet.* 2018;50: 1112–1121. doi:10.1038/s41588-018-0147-3
30. Kline RB. *Principles and practice of structural equation modeling.* New York: Guilford Press; 2011.
31. MacKinnon DP, Krull JL, Lockwood CM. Equivalence of the Mediation, Confounding and Suppression Effect. *Prev Sci Off J Soc Prev Res.* 2000;1: 173.
32. Smith GD. Mendelian Randomization for Strengthening Causal Inference in Observational Studies: Application to Gene × Environment Interactions. *Perspect Psychol Sci J Assoc Psychol Sci.* 2010;5: 527–545. doi:10.1177/1745691610383505
33. Rosseel Y. lavaan: An R Package for Structural Equation Modeling. *J Stat Softw.* 2012;48: 1–36.
34. Chalmers P, Sigal M, Oguzhan O. SimDesign: Structure for Organizing Monte Carlo Simulation Designs. 2020. Available: <https://CRAN.R-project.org/package=SimDesign>
35. Sigal MJ, Chalmers RP. Play it again: teaching statistics with monte carlo simulation. *J Stat Educ.*

2016;24: 136–156. doi:10.1080/10691898.2016.1246953