

Figure S1. Schematic of optical path of our LITE microscope. Abbreviations are defined in the lower right hand corner. Objects in Fig. S1 not drawn to scale. Our setup has the possibility to be tetrachromatic, but we show Fig. S1 as monochromatic with 488 nm (cyan) excitation light and 509 nm (green) emission light to represent a typical GFP acquisition schematic.

Figure S2. Sample mounting chambers for use with LITE. (A) Sample Chamber A, constructed of four #1.5 22 x 22 mm coverslips and one #1.5 24 x 60 mm coverslips. The front coverslip is tilted at θ . (B) Sample Chamber B, constructed of a micro-imprinted PDMS substrate (light gray) and a #1.5 24 x 60 mm glass coverslip (dark gray). The front surface of the PDMS is tilted at θ . In (A) and (B), a three-dimensional scale bar is denoted as three orthogonal vectors along the x, y, and z axis (red, green, and blue, respectively) with 10 mm lengths. The light sheet propagates in the +y direction, and the detection axis is in the -z direction for our inverted setup. (C) Enlarged, two-dimensional view of the micro-patterned flow chamber in (B).

Figure S3. Annotated photograph of the LITE prototype. All relevant components are labeled in red, and a zoomed-in view of the stage is outlined in red for a more detailed view of the relative position of the objective relative to the cylindrical lens. Objectives are readily exchangeable.

Movie S4. Dynamic comparison of bleaching rates between Epi-illumination (left, orange) and LITE (right, blue) in NaN_3 -treated, *C. elegans* (LP148) embryonic nuclei with

fluorescently marked histone H4-EGFP. Scale bar (lower left) represents 5 μm . Each nuclear movie is internally scaled to the first frame of the movie (Fig. 4A, top image). Total amount of time (top left of each movie, minutes:seconds) and the cumulative number of frames acquired (top right of each movie) are marked. Each nucleus is identically temporally scaled, as both movies were acquired using the same acquisition parameters.

video link: <https://youtu.be/H4Alt17mRkA>

Figure S5. Image series taken from Movie S4. Images of *C. elegans* (LP148) P1 nuclei shown are selected in order to illustrate the number of frames acquired (upper right hand corner of each image) until the nuclei bleached to the specified percentage of the original intensity (left hand side of each row of images).

Movie S6. Three-dimensional projection of an *A. thaliana* seedling expressing a SAUR63:YFP construct. Images were acquired using a 60X 1.2 NA water-immersion objective with the seedlings mounted in Chamber A. Each frame was acquired with a 300 ms laser exposure, a z-step of 1 μm , and a total z-range of 27 μm . Shown in Movie S6 is a 3D projection of the stack with a 'Red Hot' false coloration (Fiji). The bounding box (dashed white lines) represents 221.87 x 221.87 x 27 μm . video link: <https://youtu.be/rPcJLFDkA0M>

Movie S7. Three-dimensional projection of multi-step timelapse image of 2-cell *C. elegans* embryo (LP447) expressing a recombinant klp-7-mNeonGreen construct. Images were acquired using a 60X 1.2 NA water-immersion objective with the embryo mounted in

Chamber A. Each frame was acquired with a 300 ms laser exposure per frame with a z-step of 0.5 μm between frames. Each timepoint consists of 43 z-steps with an average time interval of 14 s between timepoints. Shown in Movie S7 is an inverted grayscale 3D stack of the embryo. Timestamps represent minutes:seconds. The movie starts in the middle of the 2-cell stage (00:14) and ends at the beginning of the 4-cell stage (13:46) in order to show the localization of klp-7 to the centrosomes, microtubules, and chromatin during mitosis. The bounding box (dashed black lines) represents 60 x 35 x 19 μm . [video link: https://youtu.be/SQ5voP1aEZI](https://youtu.be/SQ5voP1aEZI)

Movie S8. Maximum intensity projection of a *D. melanogaster* embryo expressing an exogenous Axin-EGFP construct. Images were acquired using a 40X 1.3 NA oil-immersion objective, with the embryo mounted in a poly-lysine-coated (Ted Pella) Chamber A. Each frame was acquired with a 300 ms laser exposure, a z-step of 0.5 μm , and a total z-range of 11.5 μm . The average time between timepoints is 7.94 seconds. The timestamp (lower right) is in the format of minutes:seconds. The white scale bar represents 50 μm . Image astigmatism in this movie is a characteristic of the objective, which does not have flat field correction in order to increase the number of photons transmitted through the objective. [video link: https://youtu.be/V74Bz7JMCE4](https://youtu.be/V74Bz7JMCE4)

Movie S9. Three-dimensional projection of a fixed and stained *H. dujardini* adult. Actin fibers (green) are stained using Oregon Green-tagged phalloidin, and the cuticle (magenta) is stained using WGA. Images were acquired using a 60X 1.2 NA water-immersion objective, with the adult tardigrade mounted in Chamber A. Each frame was

acquired with a 100 ms laser exposure, a z-step of 0.5 μm , and a total z-range of 80.5 μm . [video link: https://youtu.be/HIEohjUKJB4](https://youtu.be/HIEohjUKJB4)

Movie S10. Maximum intensity projection of two mitotic HeLa cells stably expressing Hec1-EGFP to mark mitotic kinetochores. Images were acquired using a 60X 1.49 NA oil-immersion objective with the cells mounted in Chamber B. Each frame was acquired with a 200 ms laser exposure with a z-step of 0.3 μm between frames, with a total z-range of 17.4 μm . Shown in Movie S10 is a 2D maximum projection of the stack with a 'Fire' false coloration (Fiji). The timestamp (lower right) represents hours:minutes:seconds.ms since acquisition began, as well as the cumulative number of frames acquired. The movie is started after 10,000 frames in order to illustrate anaphase separation of kinetochores and subsequent reduction of Hec1-EGFP from the kinetochore from the lower cell. The upper cell is in prometaphase and serves as a visual bleaching control. [video link: https://youtu.be/FUfFdo6MUmg](https://youtu.be/FUfFdo6MUmg)

Movie S11. Maximum intensity projection (after deconvolution, eight rounds of Richardson-Lucy algorithm) of an *A. gossypii* cell expressing an exogenous fluorescent histone construct, H4-GFP, in order to visualize nuclear movement and divisions through time. Timestamps for the images are shown in the upper left (time, minutes) and upper right (cumulative number of frames acquired). Purple region of interest (ROI) in full-field image is rotated and magnified by 3.7x on right and outlined in purple. Nuclei of interest are encircled in colors, corresponding to colors in Figure 6. Birth of new nuclei at mitoses are indicated with colored arrows. [video link: https://youtu.be/4clJrlanfyA](https://youtu.be/4clJrlanfyA)

Figure S1

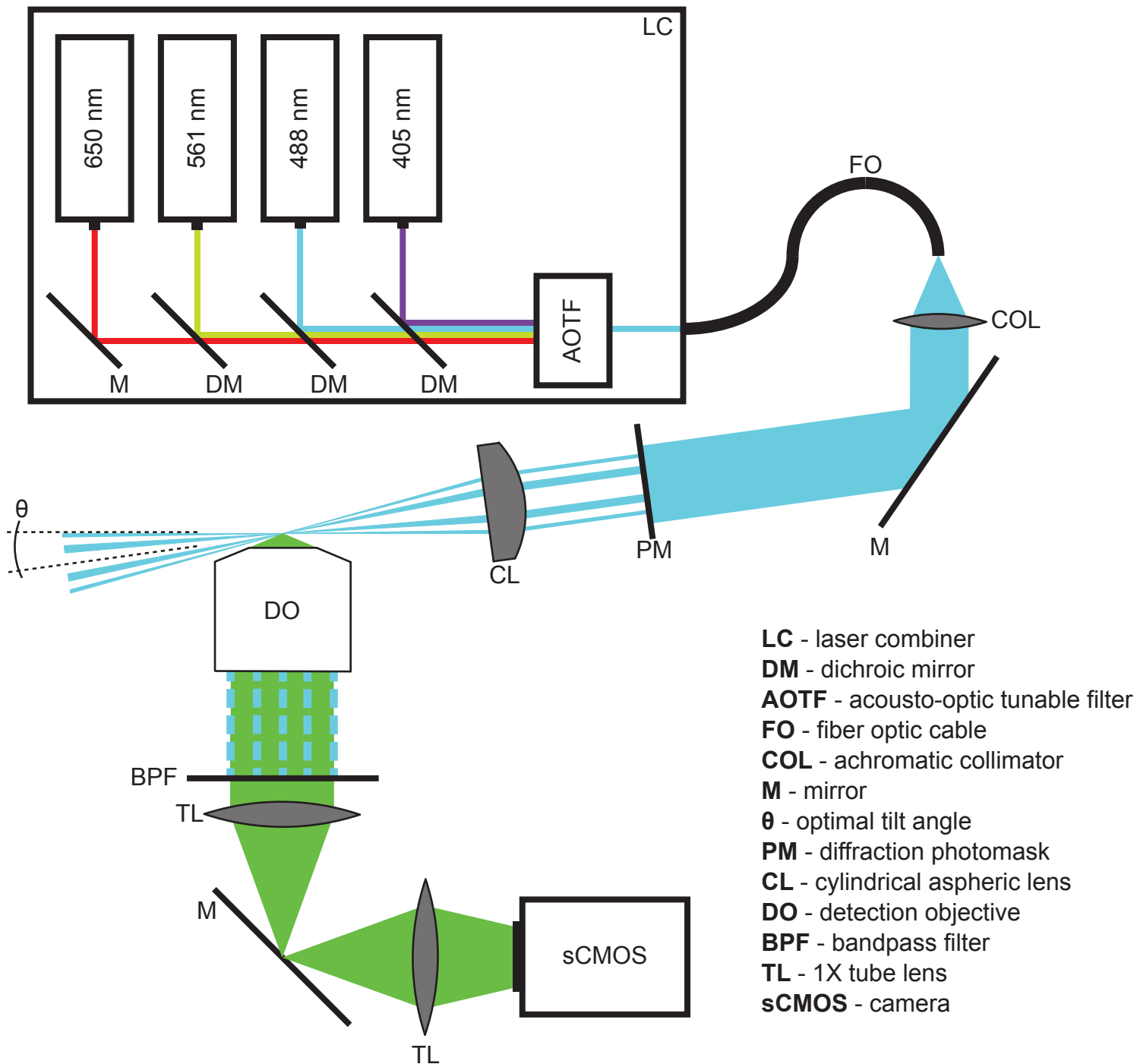

Figure S2

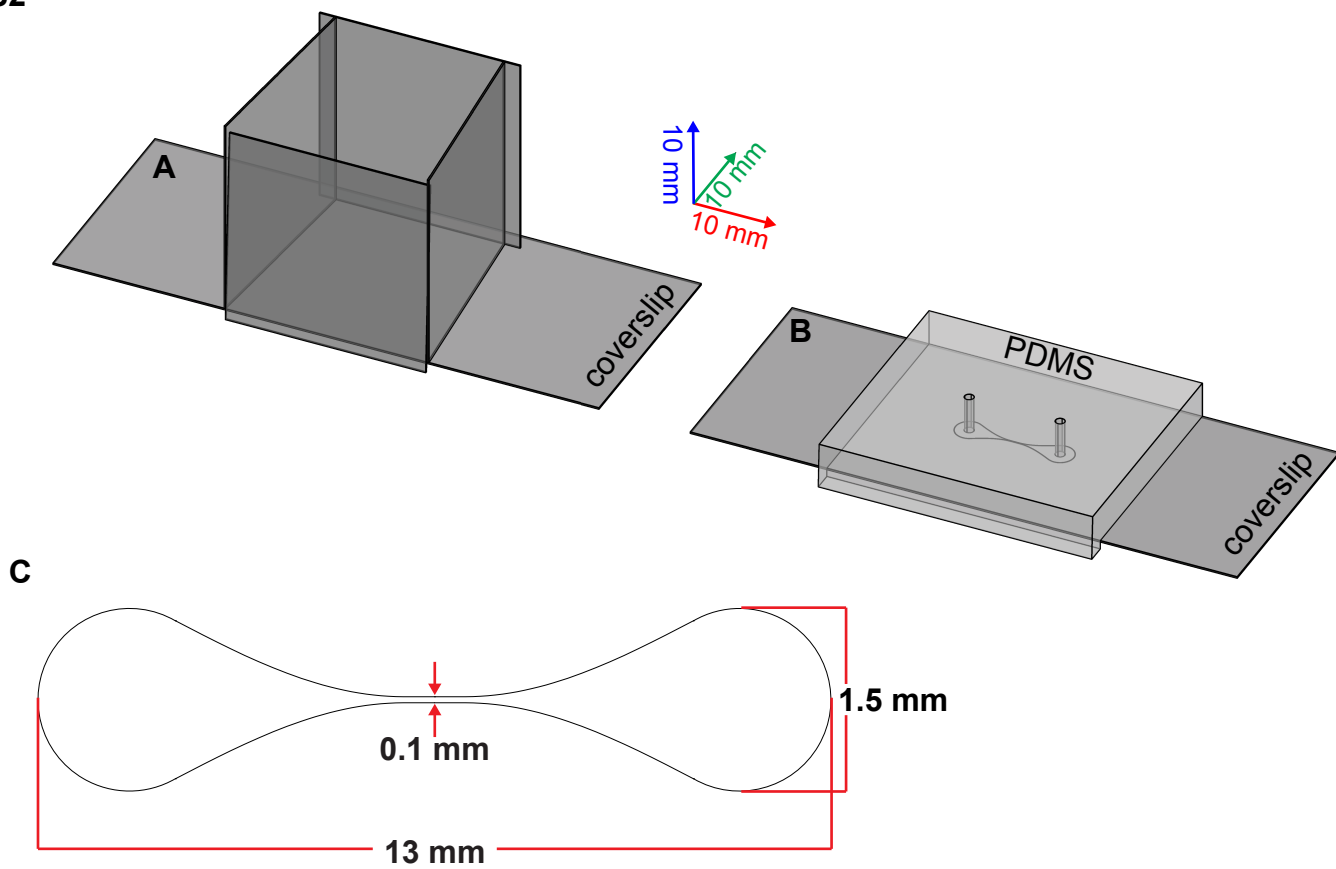

Figure S3

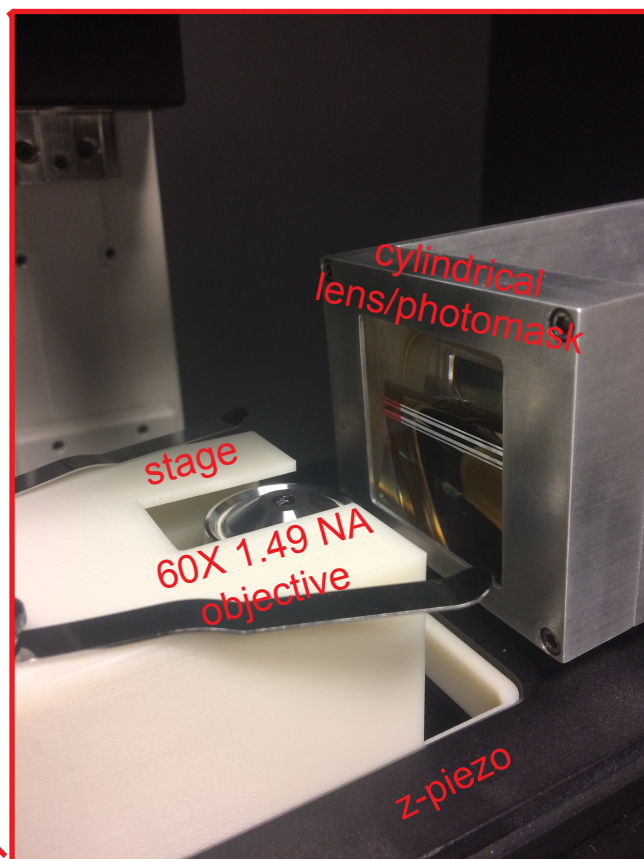
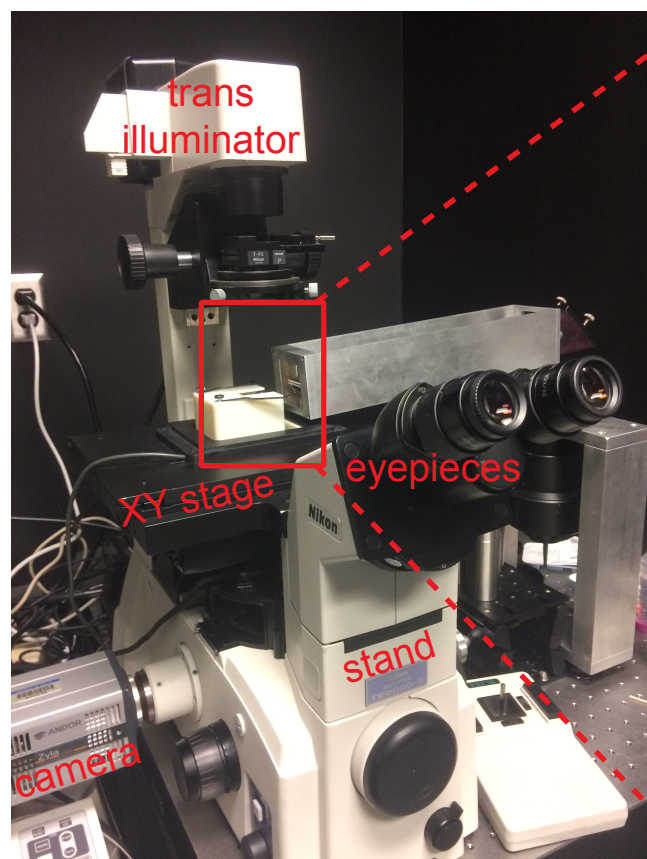

Figure S5

